

ITEM NO.	PART NUMBER	DESCRIPTION	QTY.
1	1000-0108DBL	DUAL 10-1/4" x 1" LOCKING PINS W/HAIR PINS	2
2	1000-0117	5/16" SAFETY CHAIN ASSEMBLY NEW	1
3	1000-0232	5/8"- 3 TON BOLTED ANCHOR SHACKLE	1
4	1000-0250	3 TON SWVL HOOK W/LATCH	1
5	1000-70111	OPERATOR'S MANUAL CANISTER 2.67 DIA	1
6	1360-07N	Lockease Pin for New 1360B Adj. Jib Boom	1
7	1360B-05	Decal Kit for 1360B Jib Boom	1
8	1360B-10B	SHACKLE PLATE FOR 1360B	1
9	30-8947T44	OVAL SHAPED THREADED CONN LINK 9/32	3
10	DEC10006	STAR LOGO DECAL	2

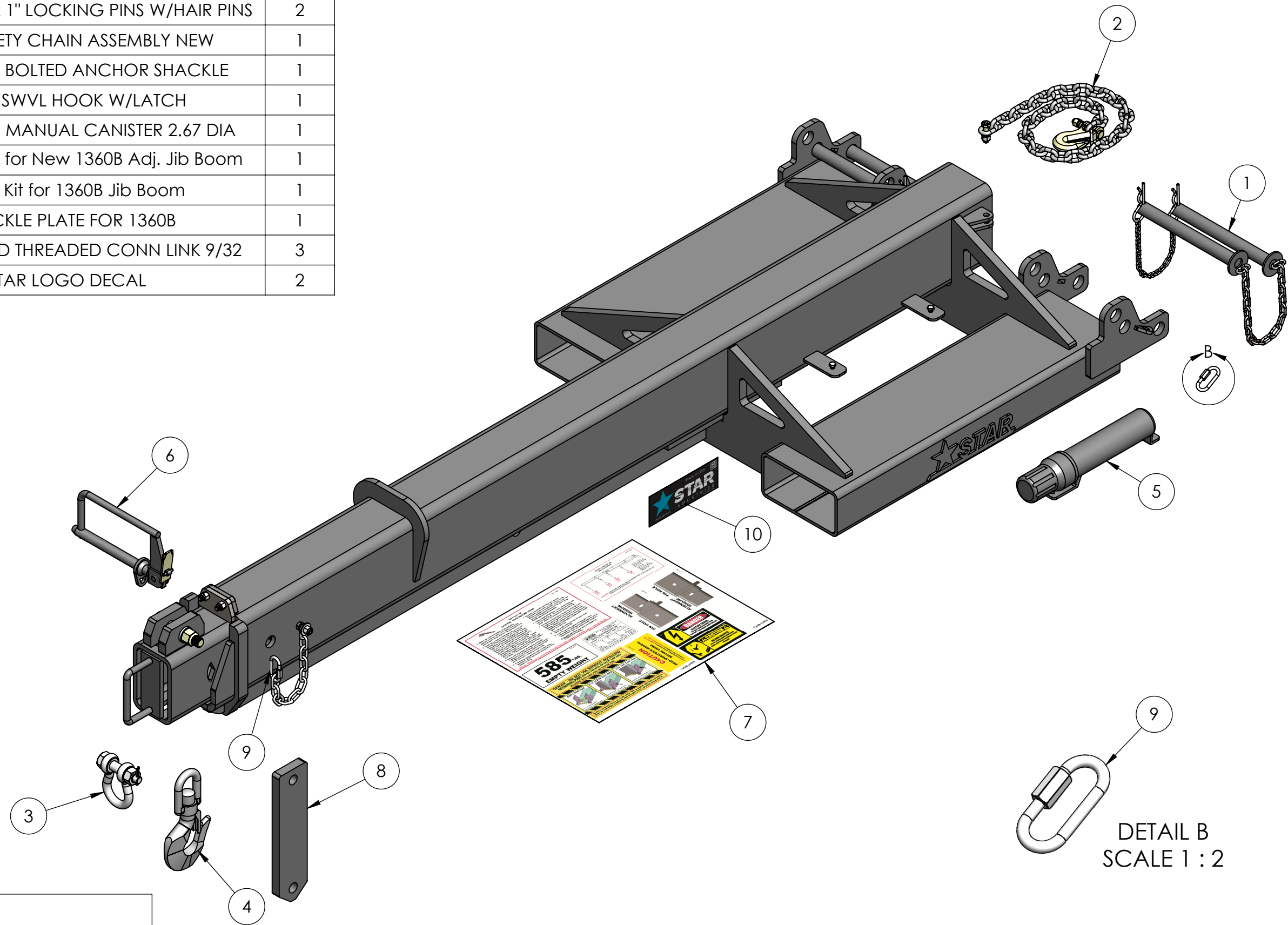

STAR INDUSTRIES
 Phone: (800) 541-1797
 (817) 485-6073
 Fax: (817) 428-6008
 4101 Garland Dr. Fort Worth, TX 76117 Email: mail@starindustries.com

Parts Diagram

PROPRIETARY AND CONFIDENTIAL
 THE INFORMATION CONTAINED IN THIS DRAWING IS THE SOLE PROPERTY OF STAR INDUSTRIES. ANY REPRODUCTION IN PART OR AS A WHOLE WITHOUT THE WRITTEN PERMISSION OF STAR INDUSTRIES IS PROHIBITED.

TITLE:	BOOM JIB-FORKLIFT EXT. 7'-12' 6K CAP	
P-WEIGHT:	591.64 lbs.	DWG. NO.
		1360B