

ITEM NO.	PART NUMBER	DESCRIPTION	QTY.
1	1000-0117	5/16" SAFETY CHAIN ASSEMBLY NEW	2
2	1385-01	SIMPLE RETAINING BAR	1
3	DEC10006	STAR LOGO DECAL	2
4	DEC50002	Decal Kit for 1385 & 1388 Safety Loading Platforms	1
5	SPL10084	NON-SLIP STRIP	2

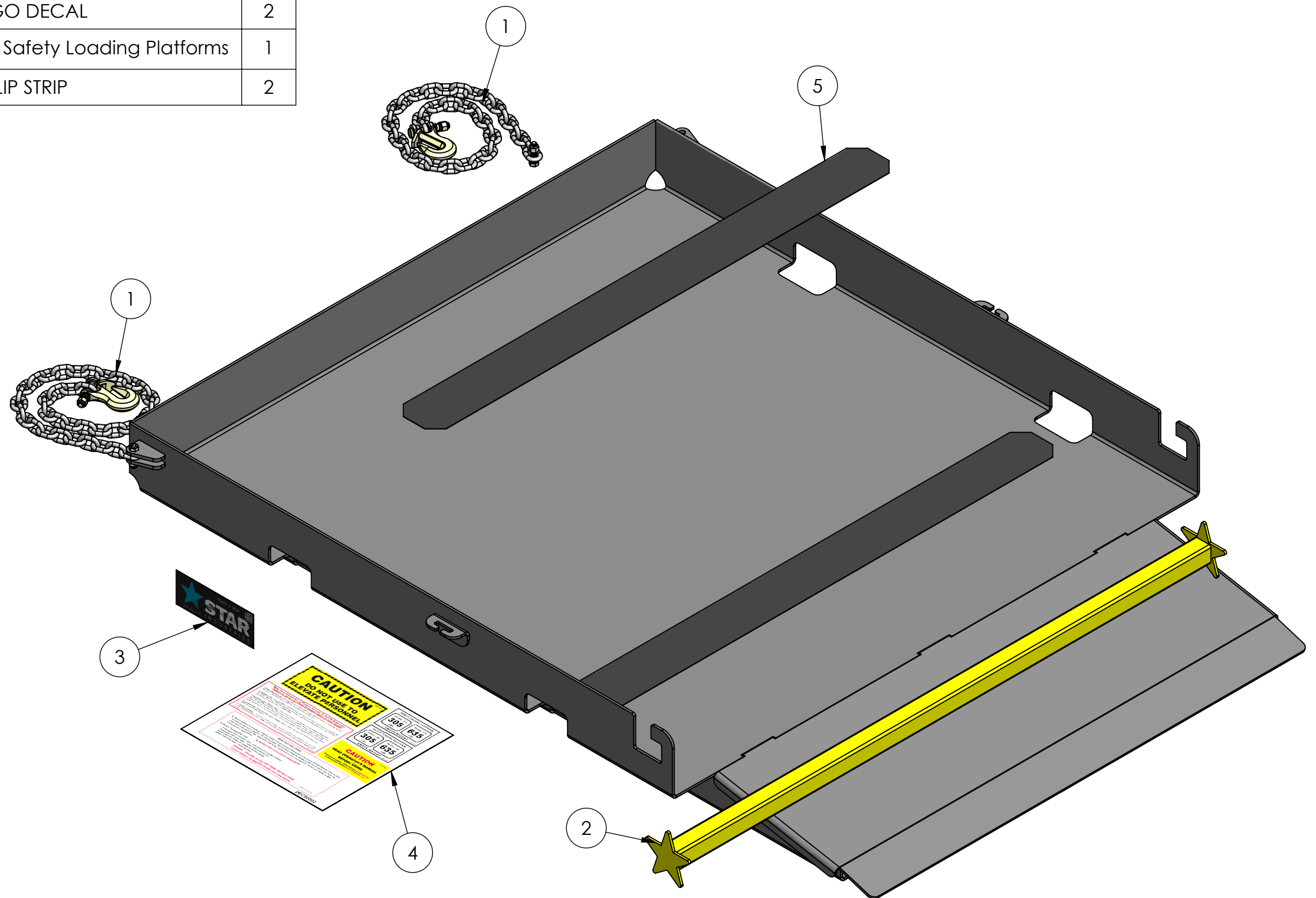



STAR
 INDUSTRIES
 Phone: (800) 541-1797
 (817) 485-6073
 Fax: (817) 428-6008
 4101 Garland Dr. Fort Worth, TX 76117 Email: mail@starindustries.com

Parts Diagram

PROPRIETARY AND CONFIDENTIAL
 THE INFORMATION CONTAINED IN THIS DRAWING IS THE SOLE PROPERTY OF STAR INDUSTRIES. ANY REPRODUCTION IN PART OR AS A WHOLE WITHOUT THE WRITTEN PERMISSION OF STAR INDUSTRIES IS PROHIBITED.

TITLE:

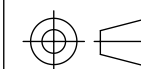
SAFETY LOADING PLATFORM



P-WEIGHT:
 313.37 lbs.

DWG. NO.

1385