

ITEM NO.	PART NUMBER	DESCRIPTION	QTY.
1	30-21625	HAIR PIN COTTER ZP #6 (206)	2
2	1000-0116	5/16" Safety Chain Assy -Includes 72" Chain, Grab hook & Nut and Bolt	1
3	1000-0233	1/2" - 2 TON BOLTED ANCHOR SHACKLE	1
4	1000-0245	2 TON SWVL HOOK W/LATCH	1
5	1000-0301	5/8" HITCH PIN WITH HAIRPIN	1
6	1000-0403	1390B Removable Stop Plate	2
7	1390B-05	Decal Kit for 1390B Lift-N-Tow	1
8	ASM10081	RSP PIN WELDMENT	2

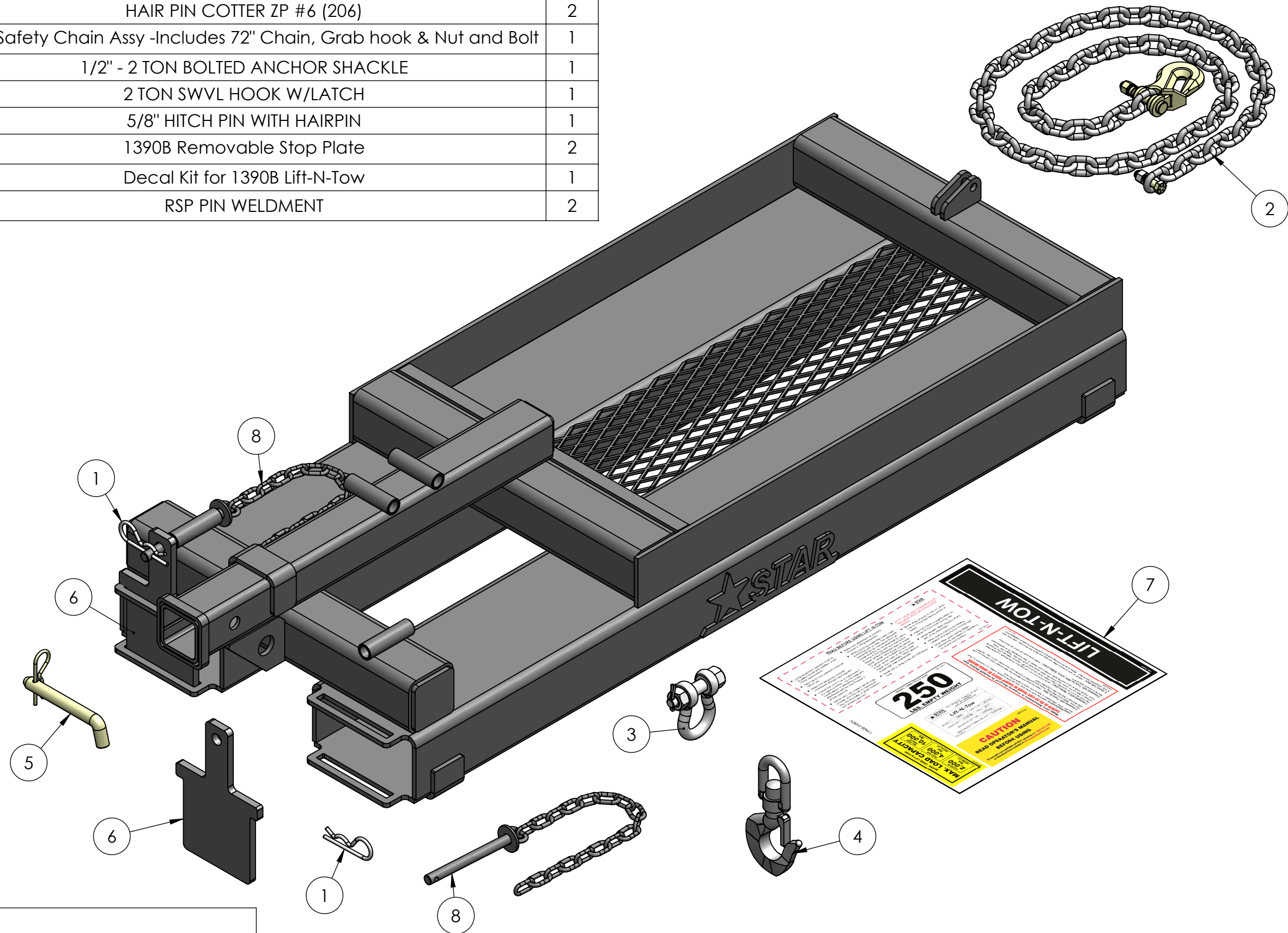



STAR
 INDUSTRIES
 Phone: (800) 541-1797
 (817) 485-6073
 Fax: (817) 428-6008
 4101 Garland Dr. Fort Worth, TX 76117 Email: mail@starindustries.com

Parts Diagram

PROPRIETARY AND CONFIDENTIAL
 THE INFORMATION CONTAINED IN THIS DRAWING IS THE SOLE PROPERTY OF STAR INDUSTRIES. ANY REPRODUCTION IN PART OR AS A WHOLE WITHOUT THE WRITTEN PERMISSION OF STAR INDUSTRIES IS PROHIBITED.

TITLE:

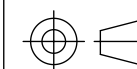
1390B LIFT N TOW



P-WEIGHT:
 244.45 lbs.

DWG. NO.

1390B