

ITEM NO.	PART NUMBER	DESCRIPTION	QTY.
1	30-21625	HAIR PIN COTTER ZP #6 (206)	2
2	1000-0116	5/16" Safety Chain Assy -Includes 72" Chain, Grab hook & Nut and Bolt	2
3	1000-0231	3/4" - 7 TON BOLTED ANCHOR SHACKLE	1
4	1000-0260	5 TON SWIVEL HOOK W/LATCH	1
5	1000-0301	5/8" HITCH PIN WITH HAIRPIN	1
6	1000-0401	1395B REMOVABLE STOP PLATE	2
7	1000-70111	OPERATOR'S MANUAL CANISTER 2.67 DIA	1
8	1395B-05	Decal Kit for 1395B Lift-N-Tow	1
9	ASM10081	RSP PIN WELDMENT	2
10	BLT10001	HEX BOLT 1/4"-20 x 3/4" ZINC	2
11	DEC10006	STAR LOGO DECAL	2
12	NUT10001	HEX NYLOCK NUT 1/4"-20 ZINC	2

DETAIL A
SCALE 1 : 1

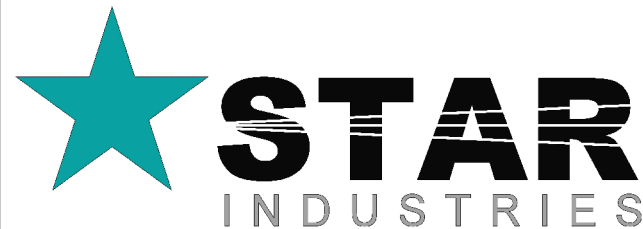
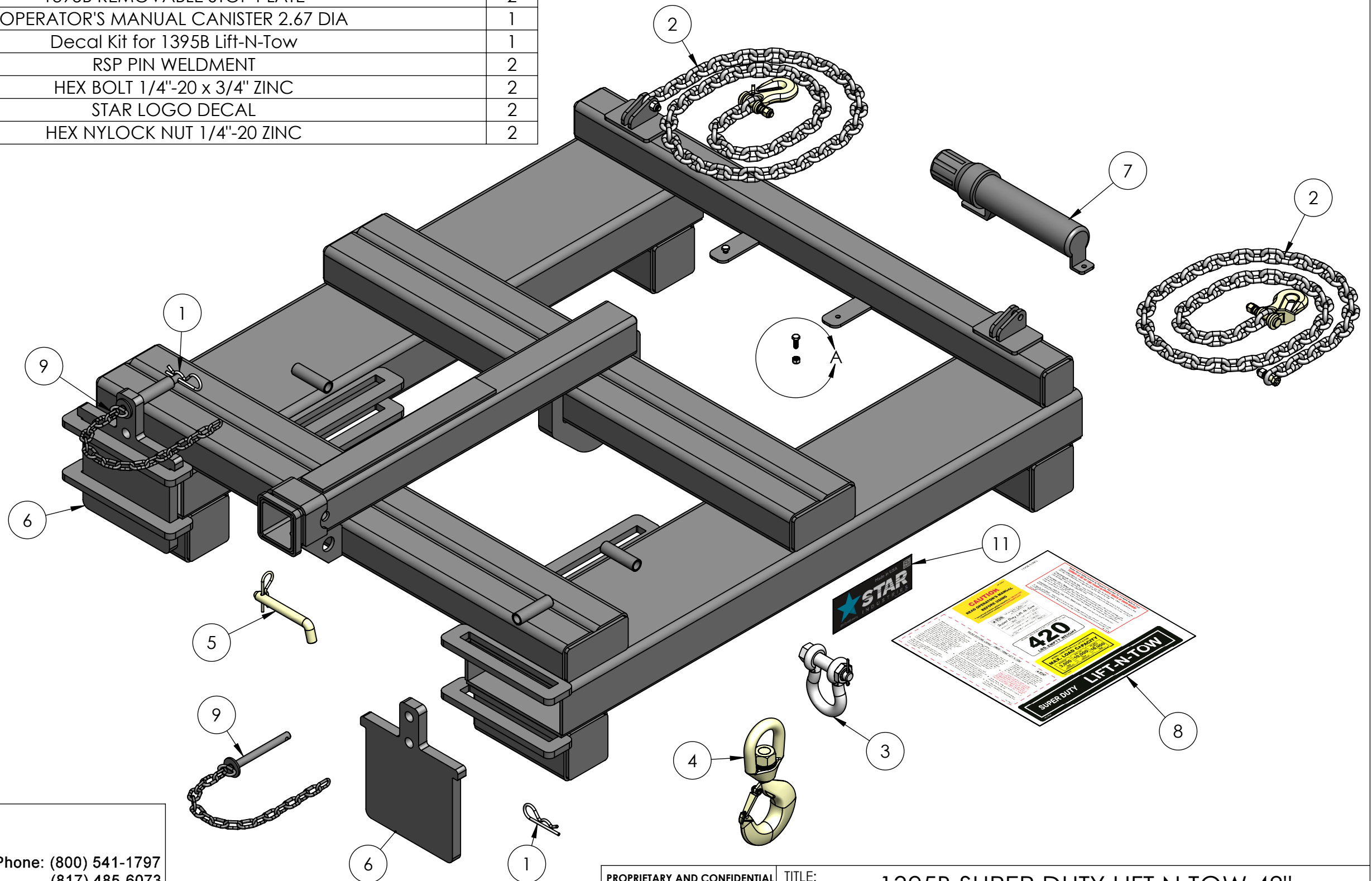
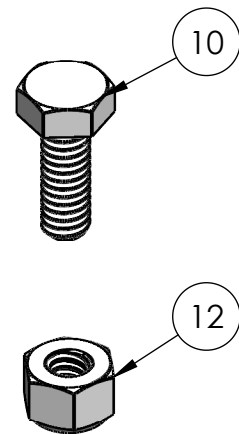

Phone: (800) 541-1797
(817) 485-6073
Fax: (817) 428-6008

4101 Garland Dr. Fort Worth, TX 76117 Email: mail@starindustries.com

Parts Diagram

PROPRIETARY AND CONFIDENTIAL
THE INFORMATION CONTAINED IN THIS
DRAWING IS THE SOLE PROPERTY OF
STAR INDUSTRIES. ANY REPRODUCTION
IN PART OR AS A WHOLE WITHOUT
THE WRITTEN PERMISSION OF STAR
INDUSTRIES IS PROHIBITED.

TITLE:

1395B SUPER DUTY LIFT N TOW 48"

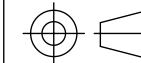

P-WEIGHT:
473.84 lbs.

DWG. NO.

1395B