

ITEM NO.	PART NUMBER	DESCRIPTION	QTY.
1	30-8947T44	OVAL SHAPED THREADED CONN LINK 9/32	2
2	1000-0108DBL	DUAL 10-1/4" x 1" LOCKING PINS W/HAIR PINS	2
3	1000-0117	5/16" SAFETY CHAIN ASSEMBLY NEW	1
4	DEC10000	DANGER - RETAINING PIN	2
5	DEC10001	CAUTION - READ OPERATOR'S MANUAL	1
6	DEC10006	STAR LOGO DECAL	2
7	DEC10018	SECURE TO FORKLIFT DECAL	1
8	DEC10144	LOOSE MATERIAL BUCKET DECAL	1

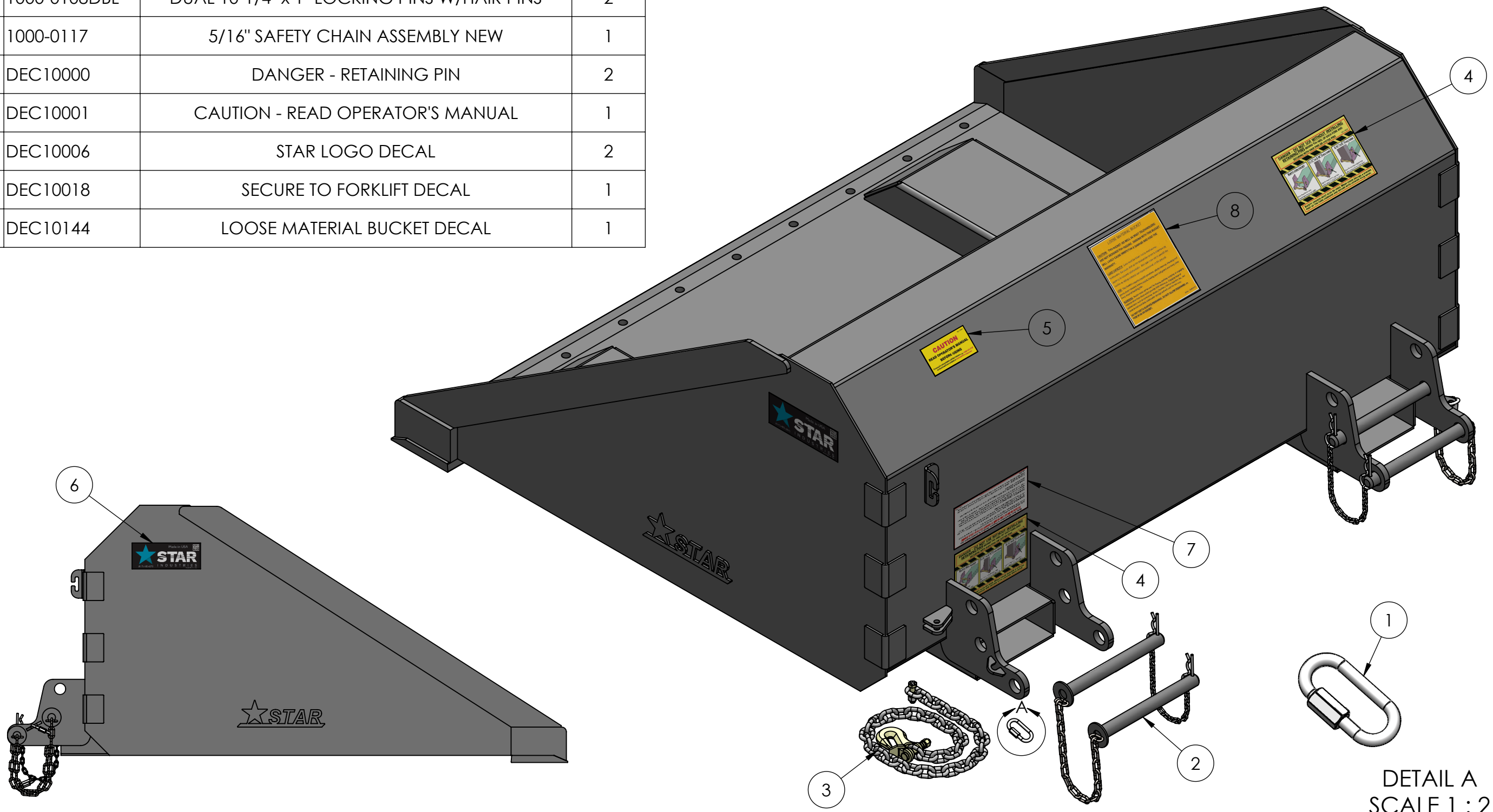



STAR
 INDUSTRIES
 Phone: (800) 541-1797
 (817) 485-6073
 Fax: (817) 428-6008
 4101 Garland Dr. Fort Worth, TX 76117 Email: mail@starindustries.com

Parts Diagram

PROPRIETARY AND CONFIDENTIAL
 THE INFORMATION CONTAINED IN THIS DRAWING IS THE SOLE PROPERTY OF STAR INDUSTRIES. ANY REPRODUCTION IN PART OR AS A WHOLE WITHOUT THE WRITTEN PERMISSION OF STAR INDUSTRIES IS PROHIBITED.

TITLE:

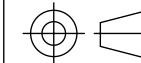
60" HD Slip-On Forklift Bucket -1.0cy



P-WEIGHT:
 564.97 lbs.

DWG. NO.

1400B