

| ITEM NO. | PART NUMBER  | DESCRIPTION                                | QTY. |
|----------|--------------|--|------|
| 1        | 30-8947T44   | OVAL SHAPED THREADED CONN LINK 9/32        | 2    |
| 2        | 1000-0108DBL | DUAL 10-1/4" x 1" LOCKING PINS W/HAIR PINS | 2    |
| 3        | 1000-0117    | 5/16" SAFETY CHAIN ASSEMBLY NEW            | 1    |
| 4        | DEC10000     | DANGER - RETAINING PIN                     | 2    |
| 5        | DEC10001     | CAUTION - READ OPERATOR'S MANUAL           | 1    |
| 6        | DEC10006     | STAR LOGO DECAL                            | 2    |
| 7        | DEC10018     | SECURE TO FORKLIFT DECAL                   | 1    |
| 8        | DEC10144     | LOOSE MATERIAL BUCKET DECAL                | 1    |

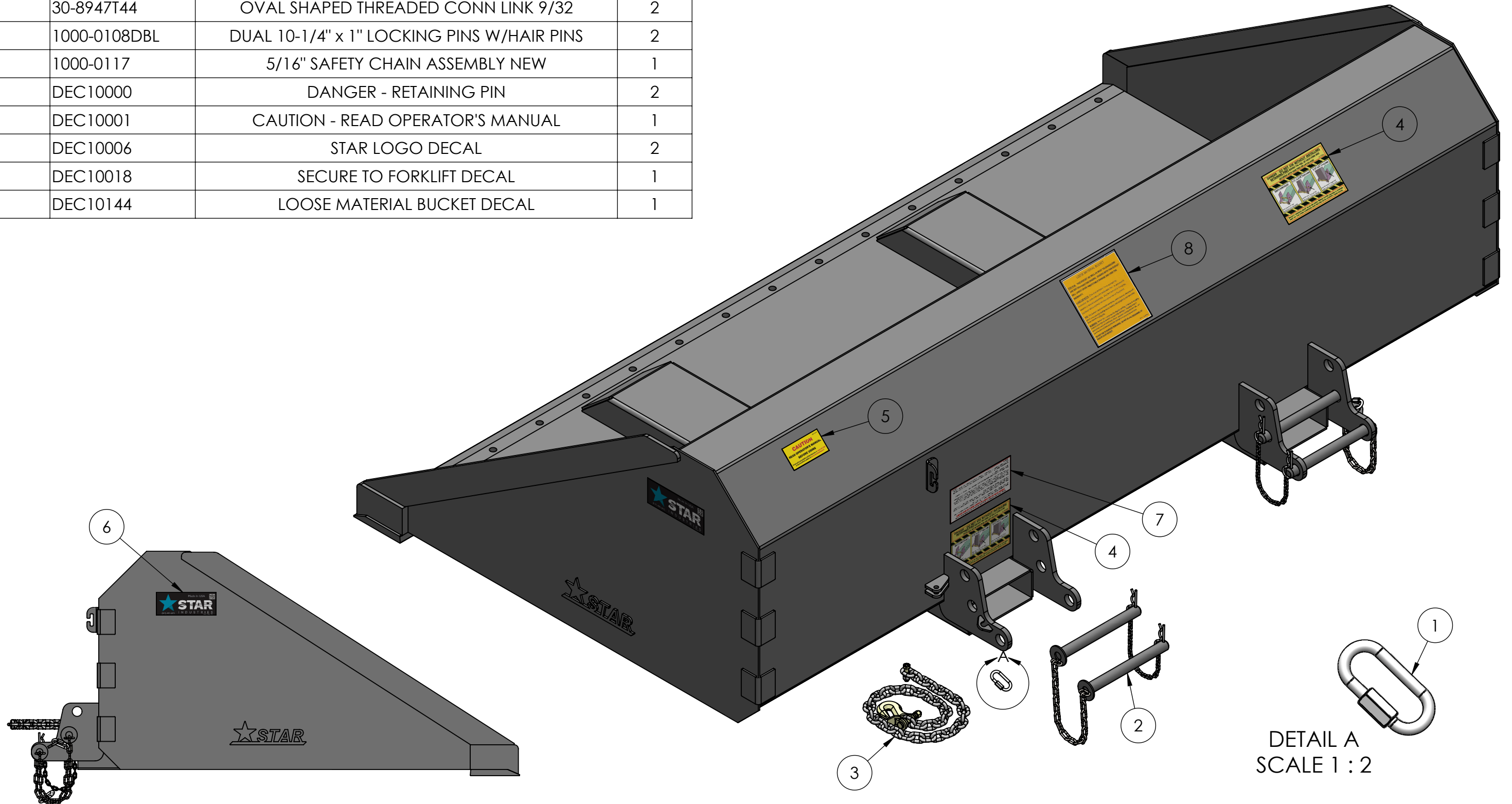



**STAR**  
 INDUSTRIES  
 Phone: (800) 541-1797  
 (817) 485-6073  
 Fax: (817) 428-6008  
 4101 Garland Dr. Fort Worth, TX 76117 Email: mail@starindustries.com

## Parts Diagram

**PROPRIETARY AND CONFIDENTIAL**  
 THE INFORMATION CONTAINED IN THIS DRAWING IS THE SOLE PROPERTY OF STAR INDUSTRIES. ANY REPRODUCTION IN PART OR AS A WHOLE WITHOUT THE WRITTEN PERMISSION OF STAR INDUSTRIES IS PROHIBITED.

TITLE:

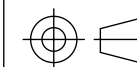
95" HD Slip-On Forklift Bucket -1.6cy



P-WEIGHT:  
 755.16 lbs.

DWG. NO.

1408B