

| ITEM NO. | PART NUMBER | DESCRIPTION | QTY. |
|----------|--------------|--|------|
| 1 | 30-8947T44 | OVAL SHAPED THREADED CONN LINK 9/32 | 2 |
| 2 | 1000-0108DBL | DUAL 10-1/4" x 1" LOCKING PINS W/HAIR PINS | 2 |
| 3 | 1000-0117 | 5/16" SAFETY CHAIN ASSEMBLY NEW | 1 |
| 4 | DEC10006 | STAR LOGO DECAL | 2 |
| 5 | DEC50000 | Decal Kit for Trash Hopper Series | 1 |

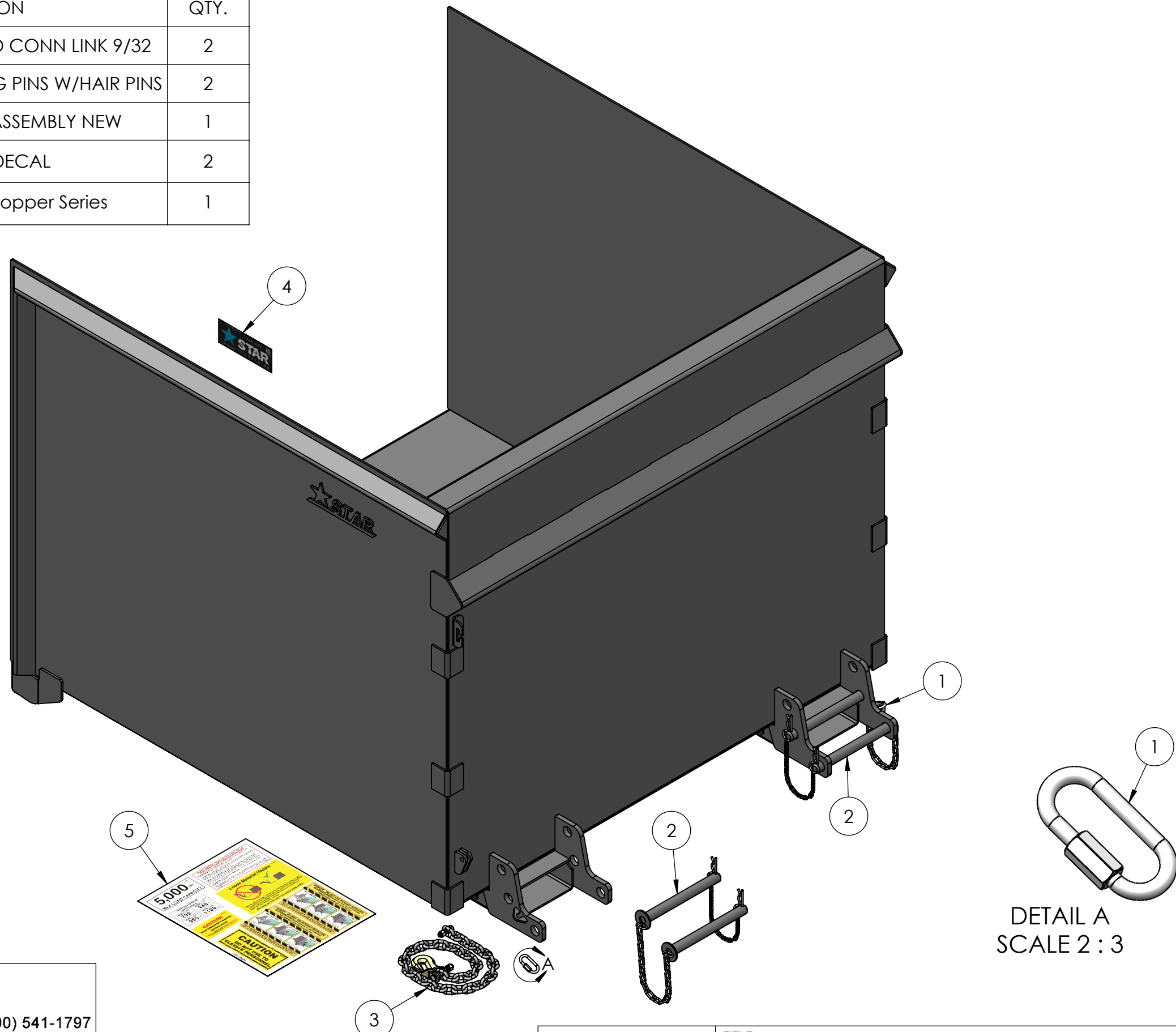

STAR
 INDUSTRIES
 Phone: (800) 541-1797
 (817) 485-6073
 Fax: (817) 428-6008
 4101 Garland Dr. Fort Worth, TX 76117 Email: mail@starindustries.com

Parts Diagram

PROPRIETARY AND CONFIDENTIAL
 THE INFORMATION CONTAINED IN THIS DRAWING IS THE SOLE PROPERTY OF STAR INDUSTRIES. ANY REPRODUCTION IN PART OR AS A WHOLE WITHOUT THE WRITTEN PERMISSION OF STAR INDUSTRIES IS PROHIBITED.

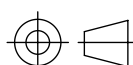
| | | |
|---|----------------------------------|------------------|
| TITLE: | TRASH HOPPER HD 4'x5'x5' - 3.7CY | |
|  | P-WEIGHT: 882.41 lbs. | DWG. NO. 1425 |