

ITEM NO.	PART NUMBER	DESCRIPTION	QTY.
1	1000-0501	8" SWIVEL CASTER	2
2	1000-0505	8" FIXED CASTER	2
3	NUT10001	HEX NYLOCK NUT 1/4"-20 ZINC	4
4	BLT10022	CARRIAGE BOLT 3/8"-16 x 5" ZINC FULL THREAD	4

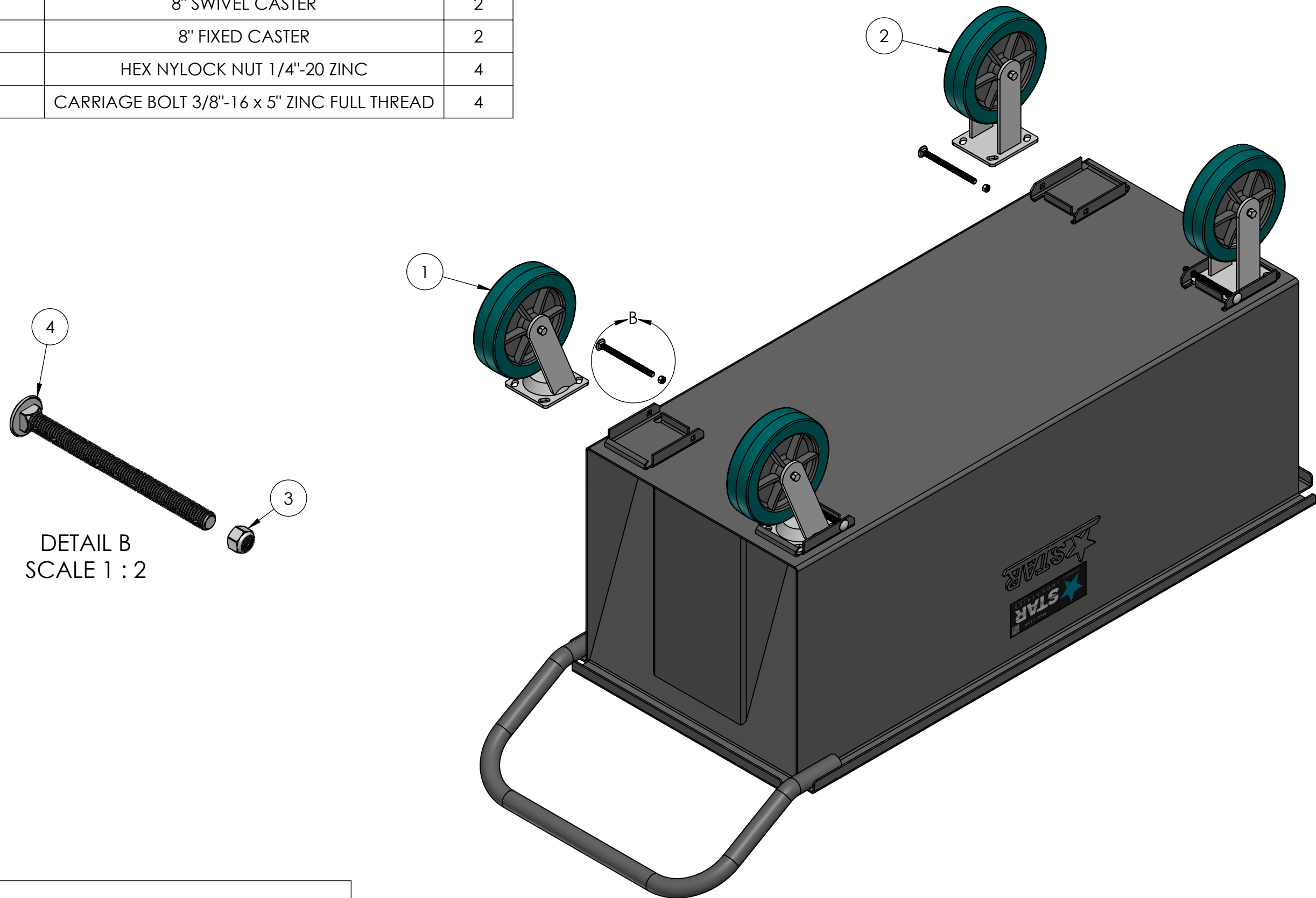



STAR
 INDUSTRIES
 Phone: (800) 541-1797
 (817) 485-6073
 Fax: (817) 428-6008
 4101 Garland Dr. Fort Worth, TX 76117 Email: mail@starindustries.com

Parts Diagram

PROPRIETARY AND CONFIDENTIAL
 THE INFORMATION CONTAINED IN THIS
 DRAWING IS THE SOLE PROPERTY OF
 STAR INDUSTRIES. ANY REPRODUCTION
 IN PART OR AS A WHOLE WITHOUT
 THE WRITTEN PERMISSION OF STAR
 INDUSTRIES IS PROHIBITED.

TITLE:

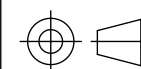
6 CU FT MORTAR BUGGY



P-WEIGHT:
 187.30 lbs.

DWG. NO.

105