

ITEM NO.	PART NUMBER	DESCRIPTION	QTY.
1	30-8947T44	OVAL SHAPED THREADED CONN LINK 9/32	2
2	1000-0101	7-1/2" x 3/4" Locking Pin w/Chain for 1664	2
3	1000-0108DBL	DUAL 10-1/4" x 1" LOCKING PINS W/HAIR PINS	2
4	1000-0117	5/16" SAFETY CHAIN ASSEMBLY NEW	2
5	1000-0232	5/8"- 3 TON BOLTED ANCHOR SHACKLE	3
6	1000-0250	3 TON SWVL HOOK W/LATCH	3
7	1000-70111	OPERATOR'S MANUAL CANISTER 2.67 DIA	1
8	1150-05	Decal Kit for 1150 Spreader Bar	2
9	BLT10001	HEX BOLT 1/4"-20 x 3/4" ZINC	2
10	DEC10000	DANGER - RETAINING PIN	1
11	DEC10001	CAUTION - READ OPERATOR'S MANUAL	1
12	DEC10006	STAR LOGO DECAL	4
13	DEC10024	OSHA DECAL	2
14	NUT10001	HEX NYLOCK NUT 1/4"-20 ZINC	2

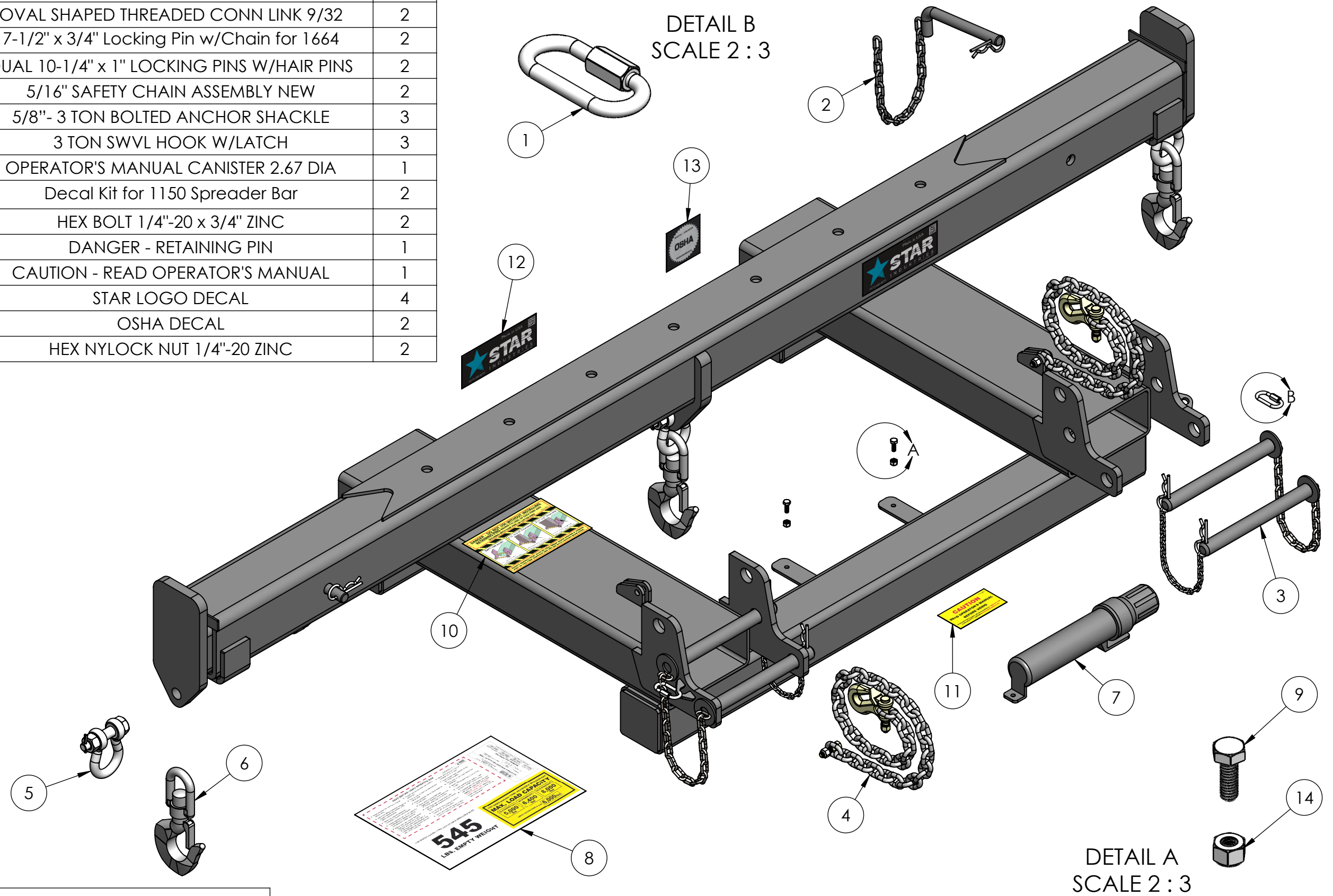

STAR
 INDUSTRIES
 Phone: (800) 541-1797
 (817) 485-6073
 Fax: (817) 428-6008
 4101 Garland Dr. Fort Worth, TX 76117 Email: mail@starindustries.com

Parts Diagram

PROPRIETARY AND CONFIDENTIAL
 THE INFORMATION CONTAINED IN THIS DRAWING IS THE SOLE PROPERTY OF STAR INDUSTRIES. ANY REPRODUCTION IN PART OR AS A WHOLE WITHOUT THE WRITTEN PERMISSION OF STAR INDUSTRIES IS PROHIBITED.

TITLE:	1150C 8'-12' ADJ SPREADER BAR	
P-WEIGHT:	562.80 lbs.	DWG. NO.
		1150C