

ITEM NO.	PART NUMBER	DESCRIPTION	QTY.
1	1000-0108DBL	DUAL 10-1/4" x 1" LOCKING PINS W/HAIR PINS	2
2	1000-0117	5/16" SAFETY CHAIN ASSEMBLY NEW	9
3	1155-05	Decal Kit for 1155 Wire Mesh Handler	2
4	DEC10000	DANGER - RETAINING PIN	1
5	DEC10001	CAUTION - READ OPERATOR'S MANUAL	2
6	DEC10006	STAR LOGO DECAL	4
7	DEC10018	SECURE TO FORKLIFT DECAL	2
8	DEC10268	1155 LIFTING CAUTION	2
9	DEC10269	1155 LIFTING CAUTION - SPANISH	2

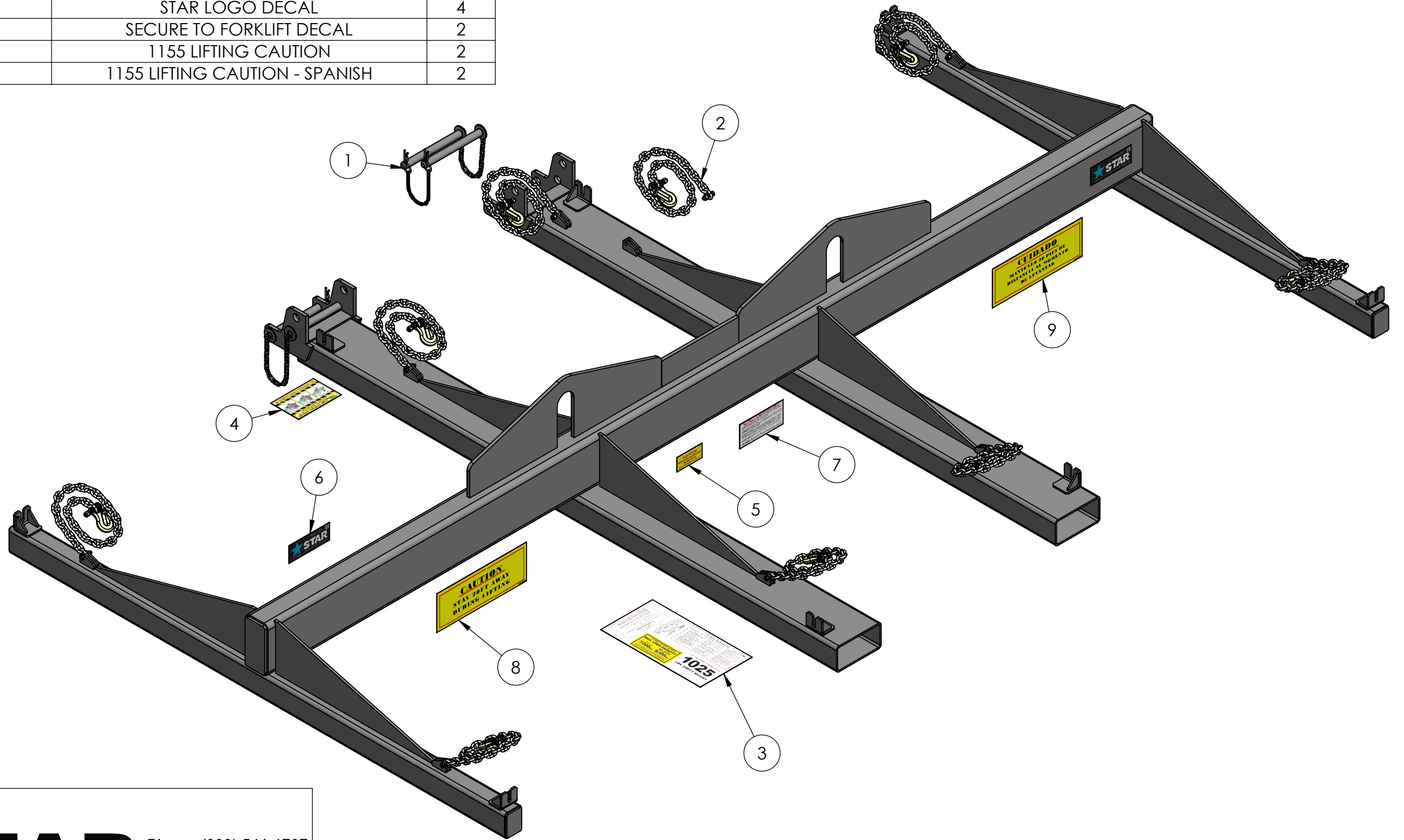



STAR
 INDUSTRIES
 Phone: (800) 541-1797
 (817) 485-6073
 Fax: (817) 428-6008
 4101 Garland Dr. Fort Worth, TX 76117 Email: mail@starindustries.com

Parts Diagram

PROPRIETARY AND CONFIDENTIAL
 THE INFORMATION CONTAINED IN THIS DRAWING IS THE SOLE PROPERTY OF STAR INDUSTRIES. ANY REPRODUCTION IN PART OR AS A WHOLE WITHOUT THE WRITTEN PERMISSION OF STAR INDUSTRIES IS PROHIBITED.

TITLE:

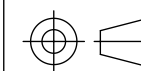
WIRE MESH HANDLER ASSEMBLY



P-WEIGHT:
 1081.27 lbs.

DWG. NO.

1155