

ITEM NO.	PART NUMBER	DESCRIPTION	QTY.
1	30-8947T44	OVAL SHAPED THREADED CONN LINK 9/32	2
2	1000-0102	8-1/2" x 3/4" Locking Pin w/Chain for 1665	2
3	1000-0108DBL	DUAL 10-1/4" x 1" LOCKING PINS W/HAIR PINS	2
4	1000-0117	5/16" SAFETY CHAIN ASSEMBLY NEW	2
5	1000-0231	3/4" - 7 TON BOLTED ANCHOR SHACKLE	3
6	1000-0260	5 TON SWIVEL HOOK W/LATCH	3
7	1000-70111	OPERATOR'S MANUAL CANISTER 2.67 DIA	1
8	1160-05	Decal Kit for 1160 Spreader Bar	2
9	BLT10001	HEX BOLT 1/4"-20 x 3/4" ZINC	2
10	BLT10014	HEX BOLT 1/2"-13 x 1-1/2" GR8 BLACK OXIDE	16
11	DEC10000	DANGER - RETAINING PIN	1
12	DEC10001	CAUTION - READ OPERATOR'S MANUAL	1
13	DEC10006	STAR LOGO DECAL	4
14	DEC10024	OSHA DECAL	2
15	NUT10001	HEX NYLOCK NUT 1/4"-20 ZINC	2
16	PRT10850	1160 BOLTED SPACER BAR	4
17	WSH10005	SPLIT LOCK WASHER 1/2"	16

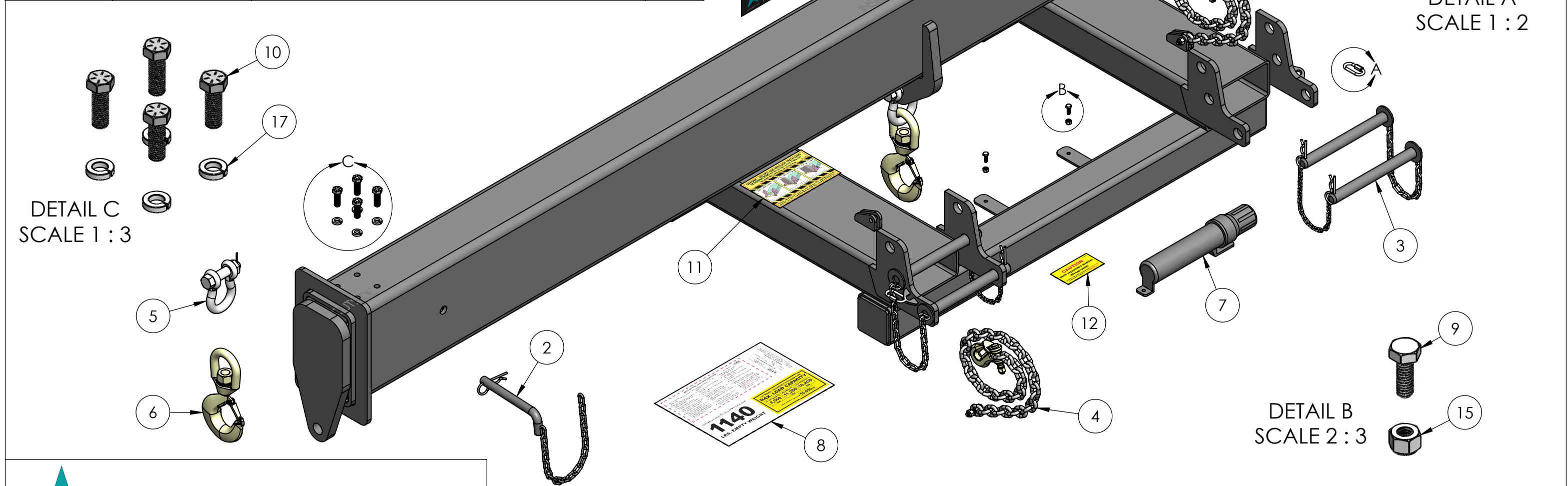

**STAR**  
 INDUSTRIES  
 Phone: (800) 541-1797  
 (817) 485-6073  
 Fax: (817) 428-6008  
 4101 Garland Dr. Fort Worth, TX 76117 Email: mail@starindustries.com

# Parts Diagram

**PROPRIETARY AND CONFIDENTIAL**  
 THE INFORMATION CONTAINED IN THIS DRAWING IS THE SOLE PROPERTY OF STAR INDUSTRIES. ANY REPRODUCTION IN PART OR AS A WHOLE WITHOUT THE WRITTEN PERMISSION OF STAR INDUSTRIES IS PROHIBITED.

TITLE: Forklift Spreader Bar 12'-20' Adjustable -Fork Pockets 39" CC	P-WEIGHT: 1152.29 lbs.	DWG. NO. 1160B
---	---------------------------	-------------------