

ITEM NO.	PART NUMBER	DESCRIPTION	QTY.
1	30-8947T44	OVAL SHAPED THREADED CONN LINK 9/32	2
2	1000-0108DBL	DUAL 10-1/4" x 1" LOCKING PINS W/HAIR PINS	2
3	1000-0117	5/16" SAFETY CHAIN ASSEMBLY NEW	1
4	1000-0231	3/4" - 7 TON BOLTED ANCHOR SHACKLE	1
5	1000-0260	5 TON SWIVEL HOOK W/LATCH	1
6	1000-70111	OPERATOR'S MANUAL CANISTER 2.67 DIA	1
7	1370B-05	Decal Kit for 1370B Lift Hook	1
8	BLT10001	HEX BOLT 1/4"-20 x 3/4" ZINC	2
9	DEC10006	STAR LOGO DECAL	2
10	NUT10001	HEX NYLOCK NUT 1/4"-20 ZINC	2

DETAIL B
SCALE 2 : 3

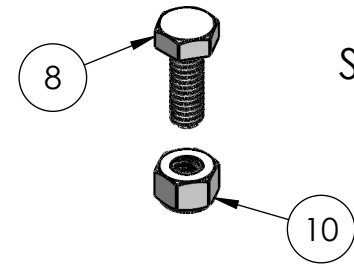

DETAIL A
SCALE 2 : 3

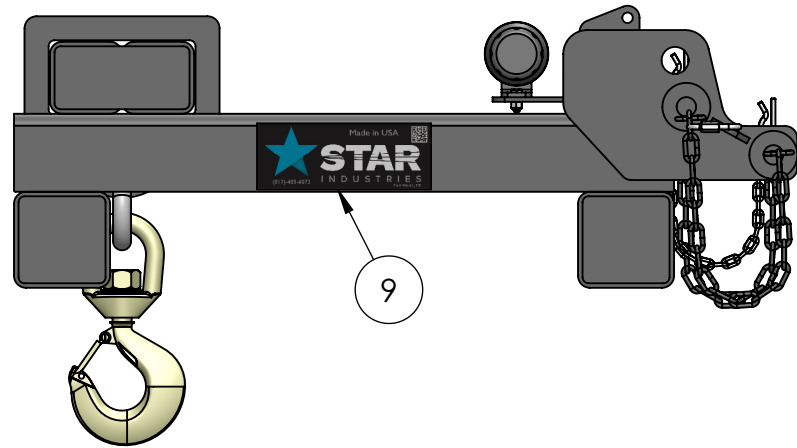
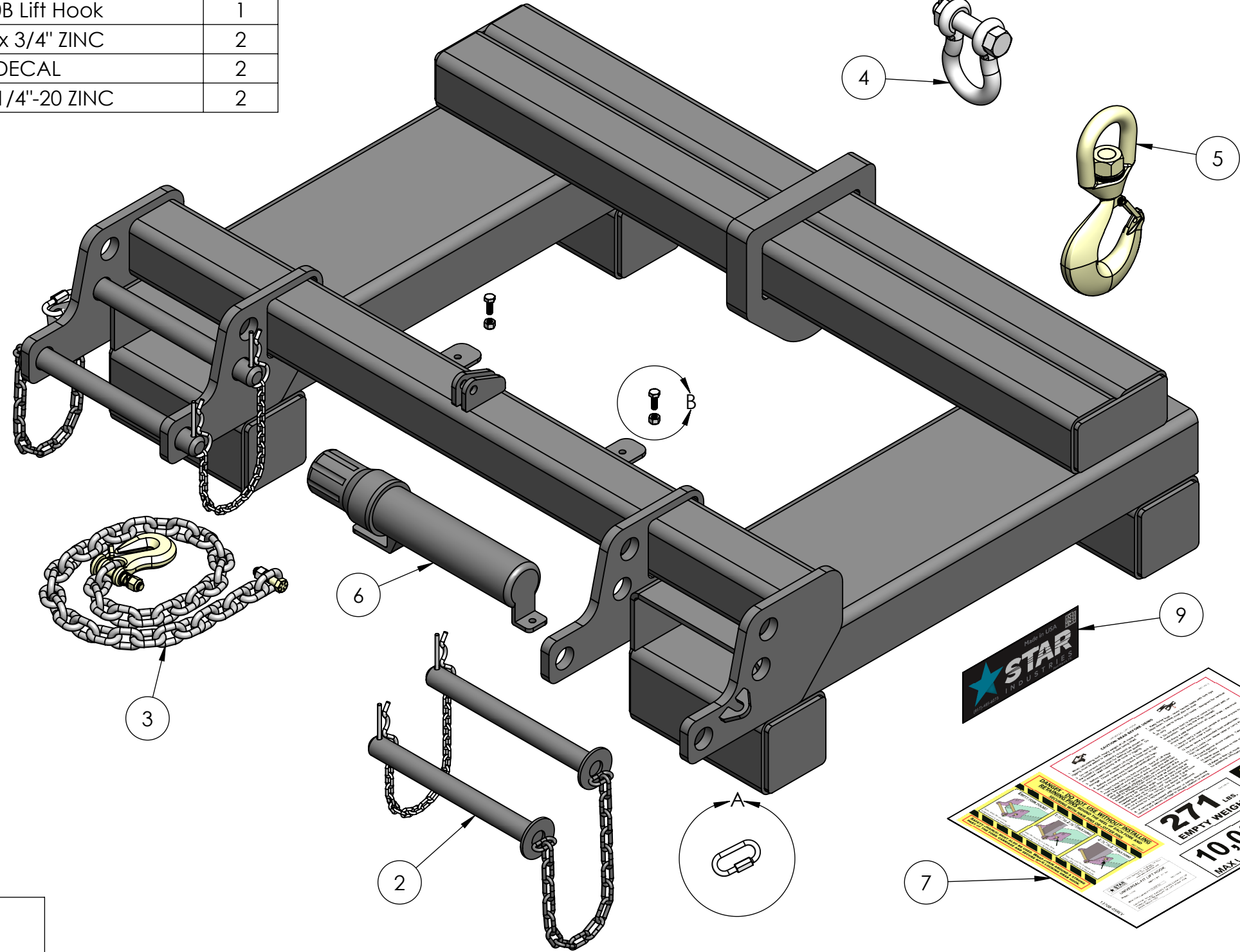
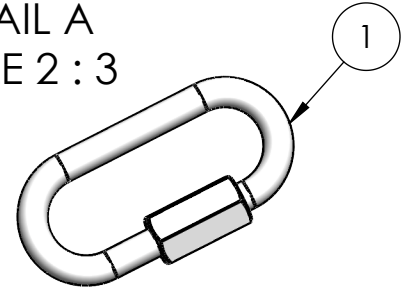

STAR INDUSTRIES
 Phone: (800) 541-1797
 (817) 485-6073
 Fax: (817) 428-6008
 4101 Garland Dr. Fort Worth, TX 76117 Email: mail@starindustries.com

Parts Diagram

PROPRIETARY AND CONFIDENTIAL
 THE INFORMATION CONTAINED IN THIS
 DRAWING IS THE SOLE PROPERTY OF
 STAR INDUSTRIES. ANY REPRODUCTION
 IN PART OR AS A WHOLE WITHOUT
 THE WRITTEN PERMISSION OF STAR
 INDUSTRIES IS PROHIBITED.

TITLE:

Lift Hook, Universal Fit 10k Cap.

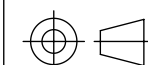

P-WEIGHT:
240.81 lbs.

DWG. NO.

1370B

