

ITEM NO.	PART NUMBER	DESCRIPTION	QTY.
1	30-8947T44	OVAL SHAPED THREADED CONN LINK 9/32	2
2	1000-0114DBL	DUAL 11-3/4" x 1" LOCKING PINS W/CHAIN	2
3	1000-0117	5/16" SAFETY CHAIN ASSEMBLY NEW	2
4	1000-0230	1-1/4" -12 TON SCREW PIN ANCHOR SHACKLE	1
5	1000-0280	11 Ton Swivel Hook w/ Latch	1
6	1000-70111	Manual Canister for Star Attachments	1
7	1377-05	Decal Kit for 1377 Lift Hook	1
8	DEC10006	STAR LOGO DECAL	2

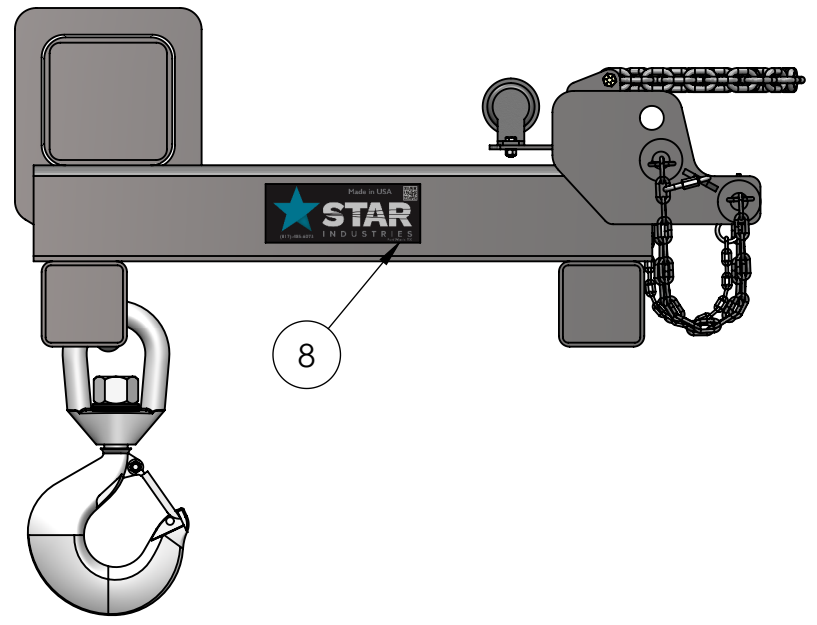
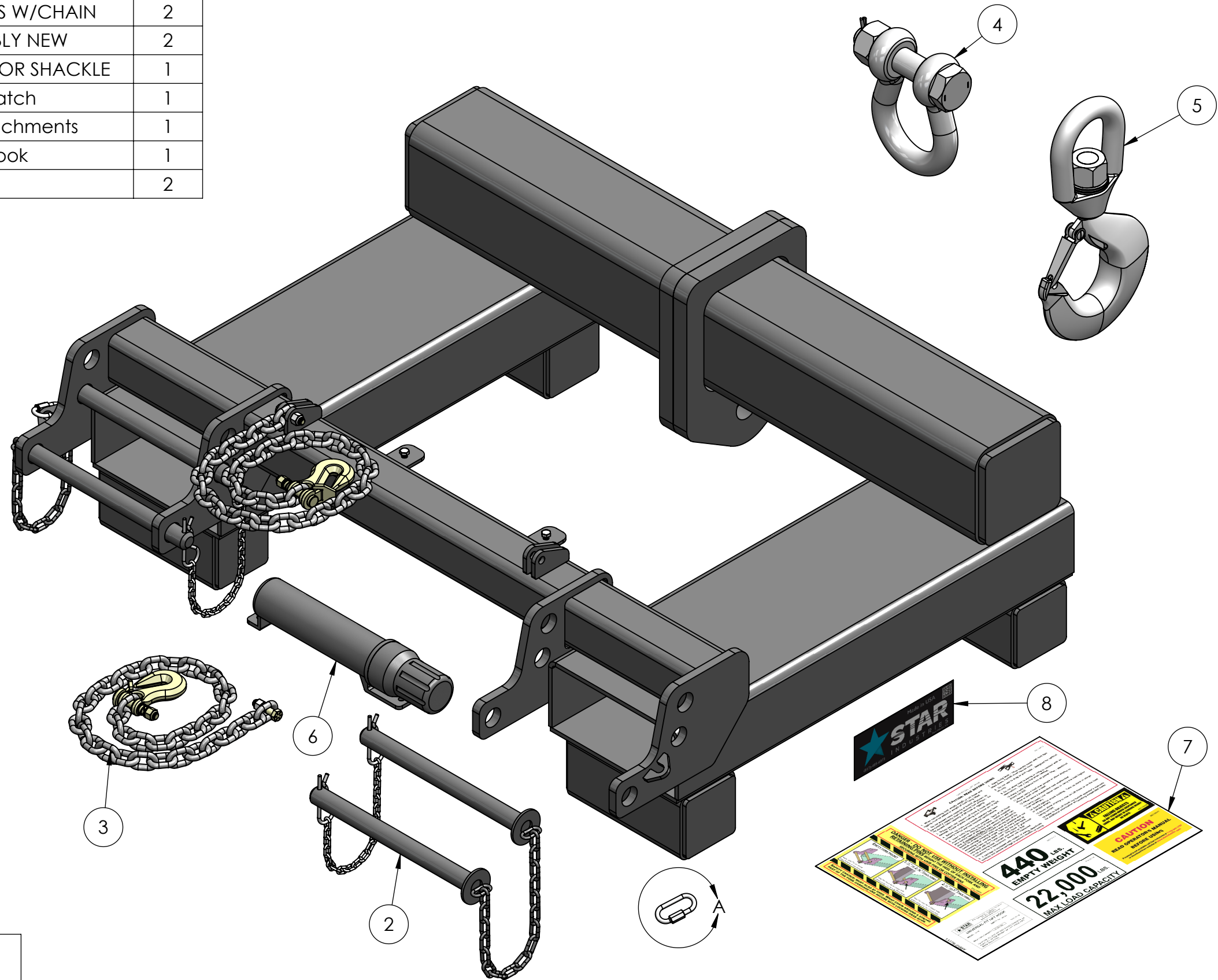

Phone: (800) 541-1797
(817) 485-6073
Fax: (817) 428-6008

4101 Garland Dr. Fort Worth, TX 76117 Email: mail@starindustries.com

Parts Diagram

PROPRIETARY AND CONFIDENTIAL THE INFORMATION CONTAINED IN THIS DRAWING IS THE SOLE PROPERTY OF STAR INDUSTRIES. ANY REPRODUCTION IN PART OR AS A WHOLE WITHOUT THE WRITTEN PERMISSION OF STAR INDUSTRIES IS PROHIBITED.	TITLE:	Lift Hook, Universal-Fit 22k Cap.	
		P-WEIGHT:	412.12 lbs.
	DWG. NO.	1377	