

ITEM NO.	PART NUMBER	DESCRIPTION	QTY.
1	15-T7550302	2" HD, swivel eye pulley 480lbs., Campbell	2
2	15-T9600435	1/4" screw pin shackle 400lbs. Campbell	3
3	1000-0108	10-1/4"x1" LOCKING PIN W/CHAIN	2
4	1000-0117	5/16" SAFETY CHAIN ASSEMBLY NEW	1
5	1800-10A	16" LATCH ASSEMBLY	1
6	1800-17	SELF DUMP ROPE	1
7	DEC10001	CAUTION - READ OPERATOR'S MANUAL	1
8	DEC10006	STAR LOGO DECAL	2
9	DEC10018	SECURE TO FORKLIFT DECAL	1
10	DEC10144	LOOSE MATERIAL BUCKET DECAL	1
11	DEC10145	STAND CLEAR OF BUCKET PATH DECAL	2

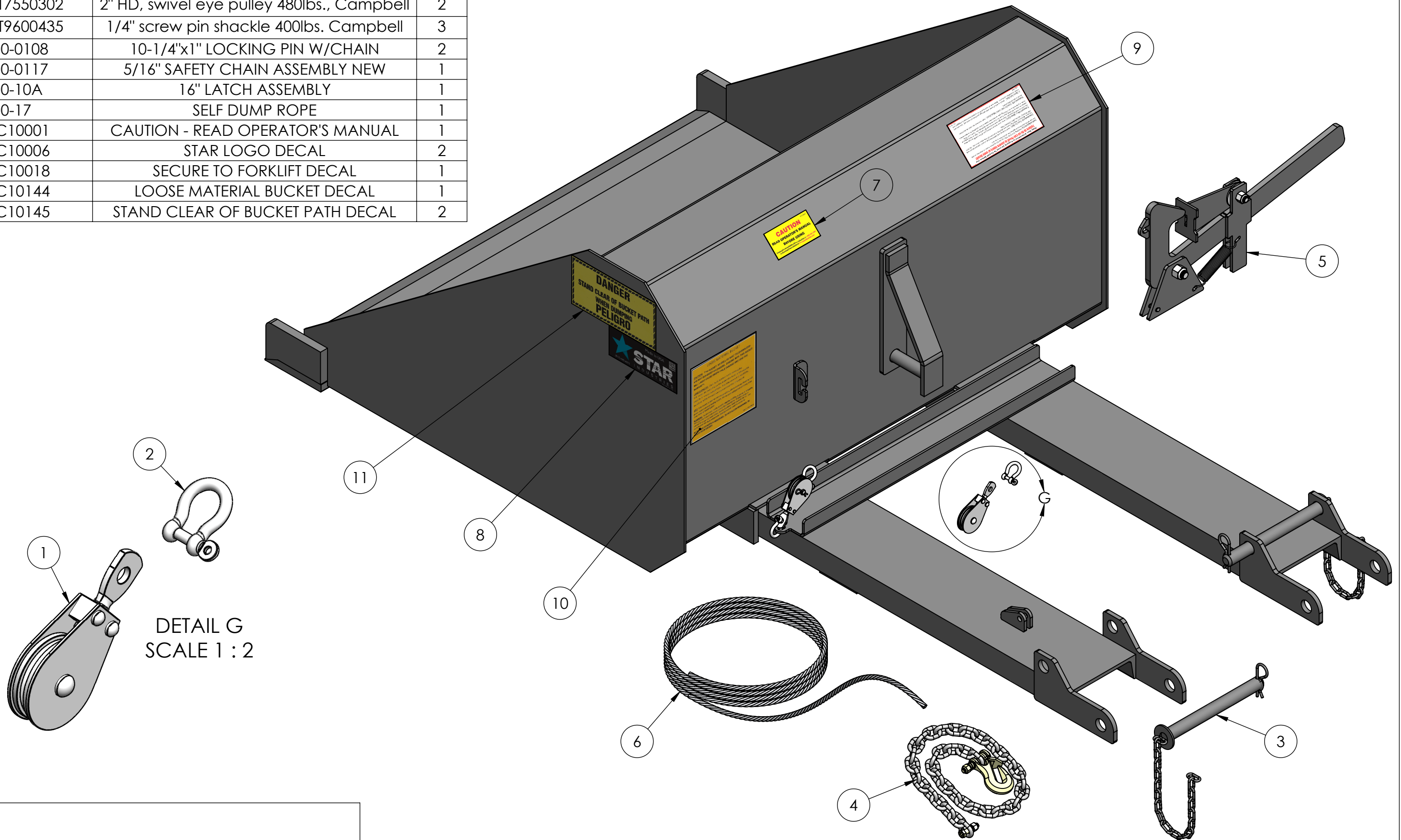



STAR
 INDUSTRIES
 Phone: (800) 541-1797
 (817) 485-6073
 Fax: (817) 428-6008
 4101 Garland Dr. Fort Worth, TX 76117 Email: mail@starindustries.com

Parts Diagram

PROPRIETARY AND CONFIDENTIAL
 THE INFORMATION CONTAINED IN THIS DRAWING IS THE SOLE PROPERTY OF STAR INDUSTRIES. ANY REPRODUCTION IN PART OR AS A WHOLE WITHOUT THE WRITTEN PERMISSION OF STAR INDUSTRIES IS PROHIBITED.

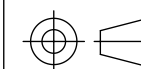
TITLE: 45" Wide Manual Self-Dump Forklift Bucket -0.5cy



P-WEIGHT:
522.08 lbs.

DWG. NO.

1445SD