

ITEM NO.	PART NUMBER	DESCRIPTION	QTY.
1	1000-0117	5/16" SAFETY CHAIN ASSEMBLY NEW	2
2	1454-05	Decal Kit for 1454 Crane Lift Box	2
3	DEC10006	STAR LOGO DECAL	2

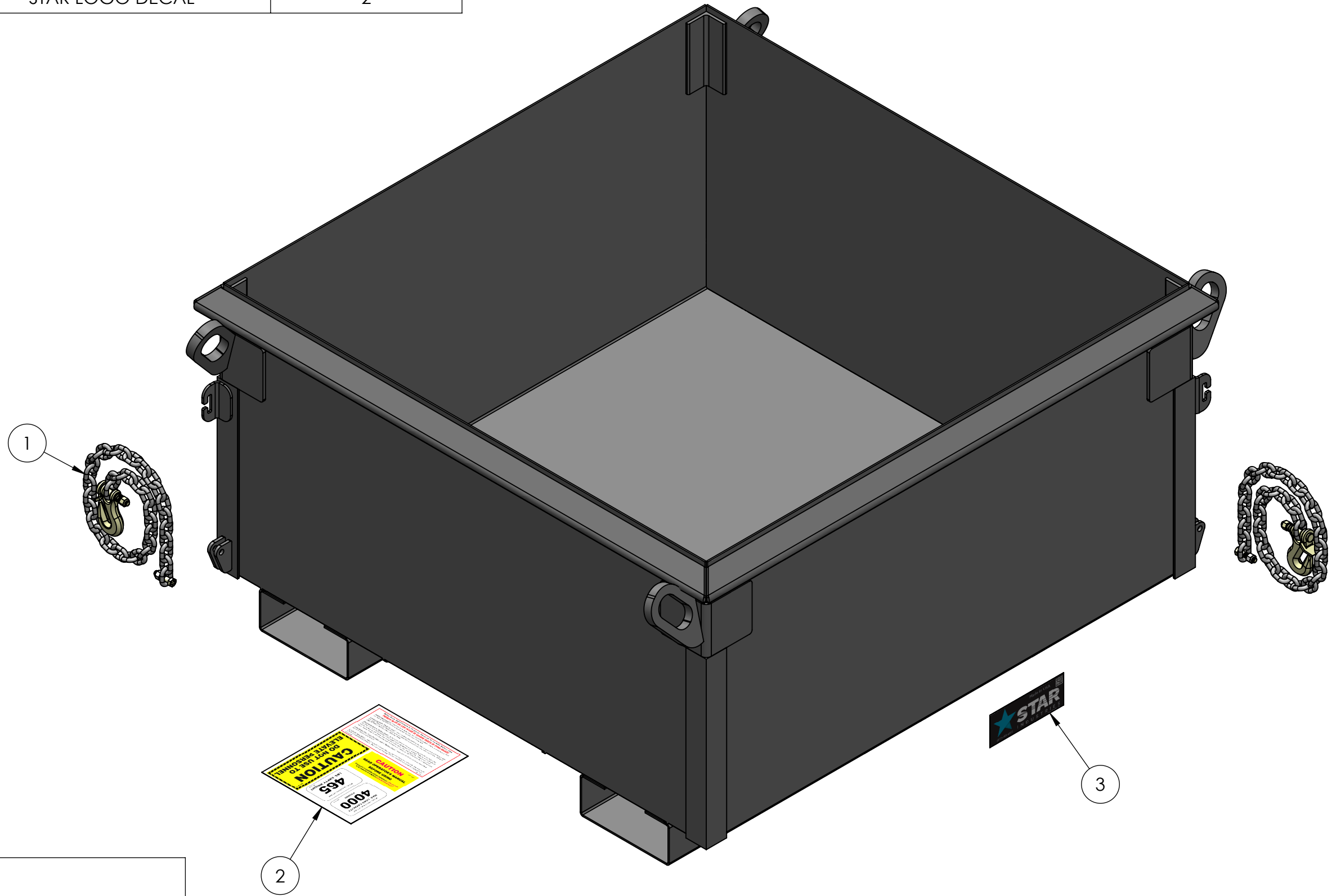



**STAR**  
 INDUSTRIES  
 Phone: (800) 541-1797  
 (817) 485-6073  
 Fax: (817) 428-6008  
 4101 Garland Dr. Fort Worth, TX 76117 Email: mail@starindustries.com

## Parts Diagram

**PROPRIETARY AND CONFIDENTIAL**  
 THE INFORMATION CONTAINED IN THIS DRAWING IS THE SOLE PROPERTY OF STAR INDUSTRIES. ANY REPRODUCTION IN PART OR AS A WHOLE WITHOUT THE WRITTEN PERMISSION OF STAR INDUSTRIES IS PROHIBITED.

TITLE:

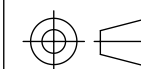
CRANE LIFT BOX 4'X4'X2' H



P-WEIGHT:  
 456.14 lbs.

DWG. NO.

1454