

ITEM NO.	PART NUMBER	DESCRIPTION	QTY.
1	170-0015B	LONG 1" PIN GRAPPLE	1
2	170-MI-0016	MINI GRAPPLE SHORT PIN	1
3	1000-0108	10-1/4"x1" LOCKING PIN W/CHAIN	2
4	1000-0117	5/16" SAFETY CHAIN ASSEMBLY NEW	1
5	1445SDH-010	SELF DUMP HYDRAULIC CYLINDER	1
6	1445SDH-012	Machine Hose Set for Self Dump Buckets	1
7	1445SDH-013	Elbow Adapter for Self Dump Buckets	2
8	1445SDH-014	Coupler set (M&F) for Self Dump Buckets 1/2" Hose	1
9	BLT10015	HEX BOLT 1/4"-20 x 2" GR8 YELLOW ZINC	2
10	DEC10001	CAUTION - READ OPERATOR'S MANUAL	1
11	DEC10006	STAR LOGO DECAL	2
12	DEC10018	SECURE TO FORKLIFT DECAL	1
13	DEC10144	LOOSE MATERIAL BUCKET DECAL	1
14	DEC10145	STAND CLEAR OF BUCKET PATH DECAL	2
15	NUT10001	HEX NYLOCK NUT 1/4"-20 ZINC	2

DETAIL F  
SCALE 2 : 5

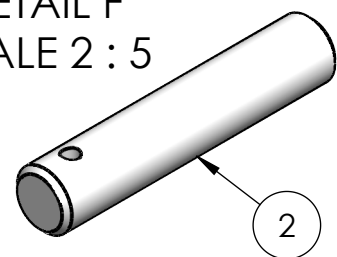

DETAIL G  
SCALE 2 : 5

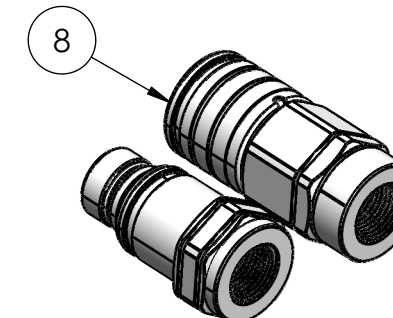
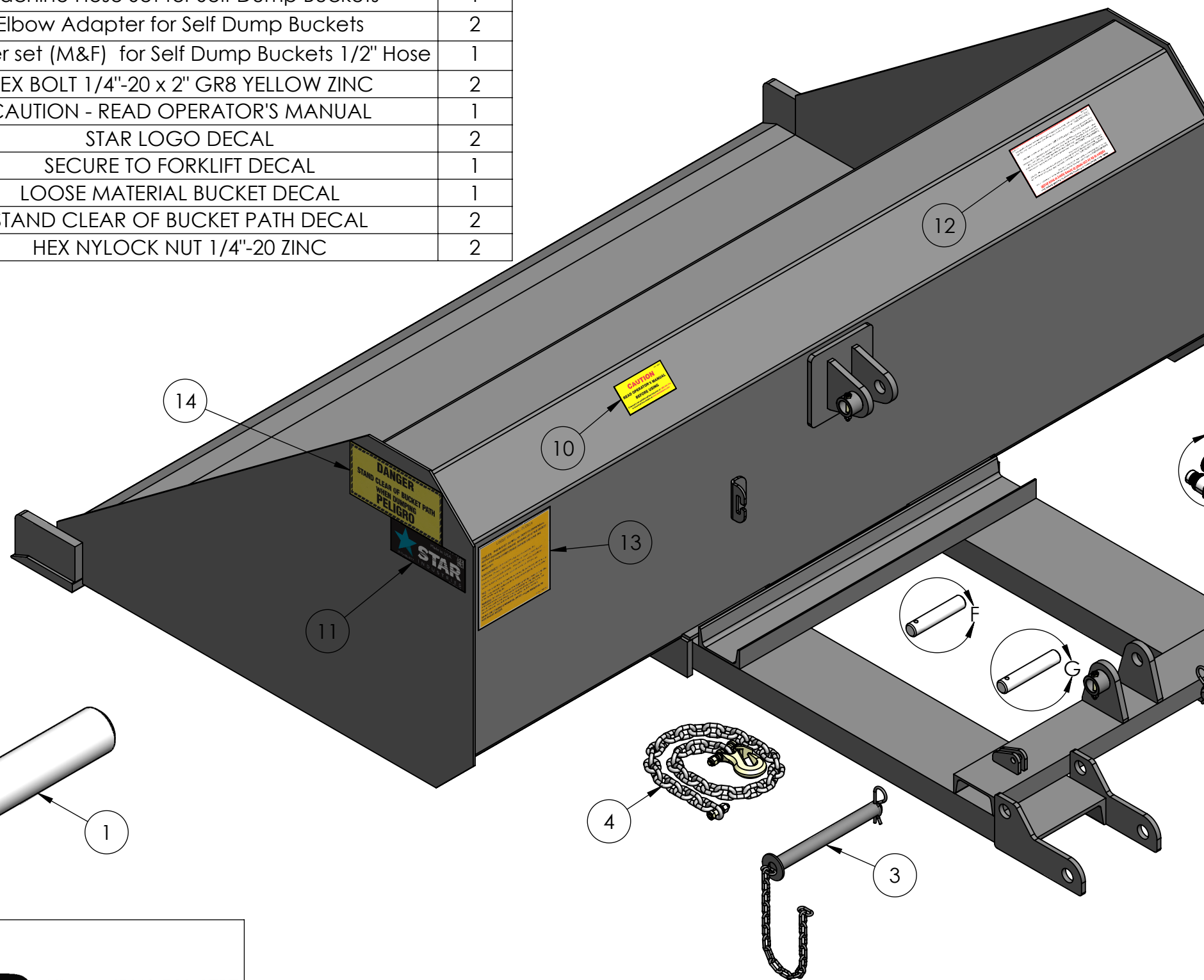
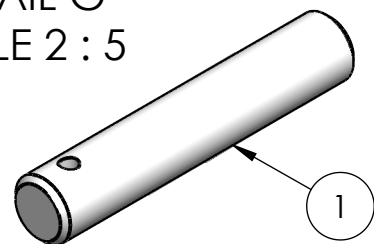

DETAIL D  
SCALE 2 : 5

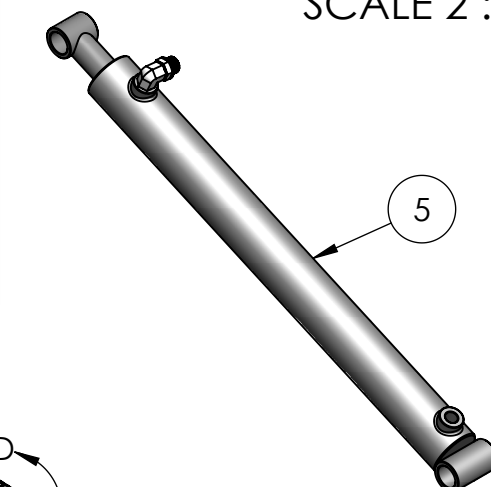

DETAIL E  
SCALE 2 : 5

**STAR INDUSTRIES**  
 Phone: (800) 541-1797  
 (817) 485-6073  
 Fax: (817) 428-6008  
 4101 Garland Dr. Fort Worth, TX 76117 Email: mail@starindustries.com

# Parts Diagram

<b>PROPRIETARY AND CONFIDENTIAL</b> THE INFORMATION CONTAINED IN THIS DRAWING IS THE SOLE PROPERTY OF STAR INDUSTRIES. ANY REPRODUCTION IN PART OR AS A WHOLE WITHOUT THE WRITTEN PERMISSION OF STAR INDUSTRIES IS PROHIBITED.	TITLE:	72" SELF DUMP HYDRAULIC BUCKET	
		P-WEIGHT:	681.23 lbs.
	DWG. NO.	1472SDH	