

ITEM NO.	PART NUMBER	DESCRIPTION	QTY.
1	170-0015B	LONG 1" PIN GRAPPLE	4
2	170-0042	GREASE ZERK 1/4"-28 TAPER	3
3	170-0046	Grapple Hose Spring Kit	1
4	170-MI-0011	MINI GRAPPLE CYL WLDMNT	1
5	170-MI-0013S	MINI GRAPPLE CYLINDER COVER (STAR)	1
6	170-MI-0016	MINI GRAPPLE SHORT PIN	1
7	170-MI-0030	MINI GRAPPLE HYD. HOSE ASSEMBLY	1
8	DEC10006	STAR LOGO DECAL	1
9	DEC10041	DANGER - PINCH	1
10	DEC10042	WARNING - HIGH PRESSURE FLUID	1

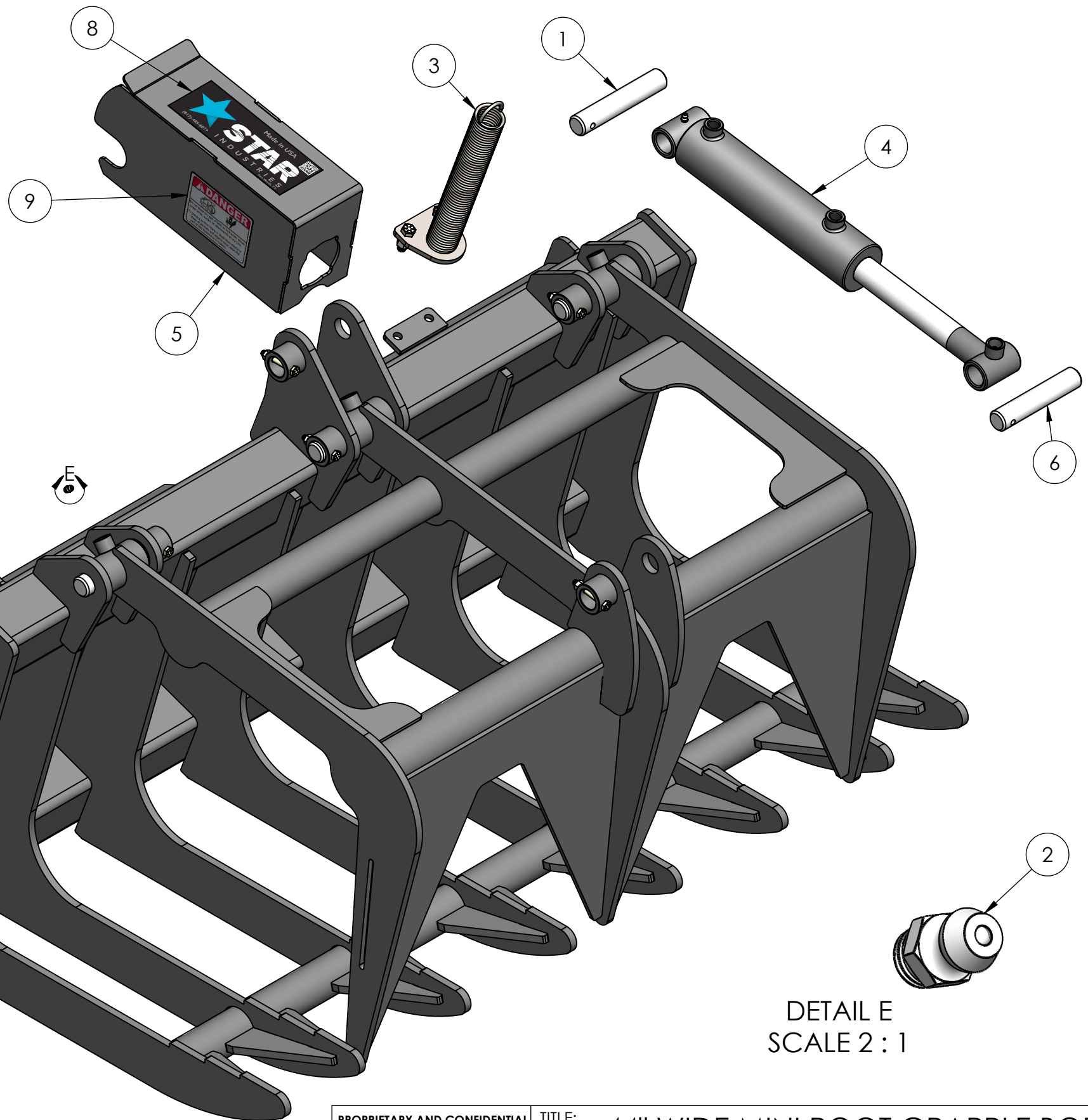

DETAIL E  
SCALE 2 : 1

**STAR**  
 INDUSTRIES  
 Phone: (800) 541-1797  
 (817) 485-6073  
 Fax: (817) 428-6008  
 4101 Garland Dr. Fort Worth, TX 76117 Email: mail@starindustries.com

## Parts Diagram

**PROPRIETARY AND CONFIDENTIAL**  
 THE INFORMATION CONTAINED IN THIS  
 DRAWING IS THE SOLE PROPERTY OF  
 STAR INDUSTRIES. ANY REPRODUCTION  
 IN PART OR AS A WHOLE WITHOUT  
 THE WRITTEN PERMISSION OF STAR  
 INDUSTRIES IS PROHIBITED.

TITLE: 44" WIDE MINI ROOT GRAPPLE BOBCAT

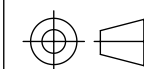

P-WEIGHT:  
368.35 lbs.

DWG. NO.  
170-MIBC-44