

ITEM NO.	PART NUMBER	DESCRIPTION	QTY.
1	170-0015B	LONG 1" PIN GRAPPLE	4
2	170-0042	GREASE ZERK 1/4"-28 TAPER	3
3	170-0046	Grapple Hose Spring Kit	1
4	170-MI-0011	MINI GRAPPLE CYL WLDMNT	1
5	170-MI-0013S	MINI GRAPPLE CYLINDER COVER (STAR)	1
6	170-MI-0016	MINI GRAPPLE SHORT PIN	1
7	170-MI-0030	MINI GRAPPLE HYD. HOSE ASSEMBLY	1
8	DEC10006	STAR LOGO DECAL	1
9	DEC10041	DANGER - PINCH	1
10	DEC10042	WARNING - HIGH PRESSURE FLUID	1

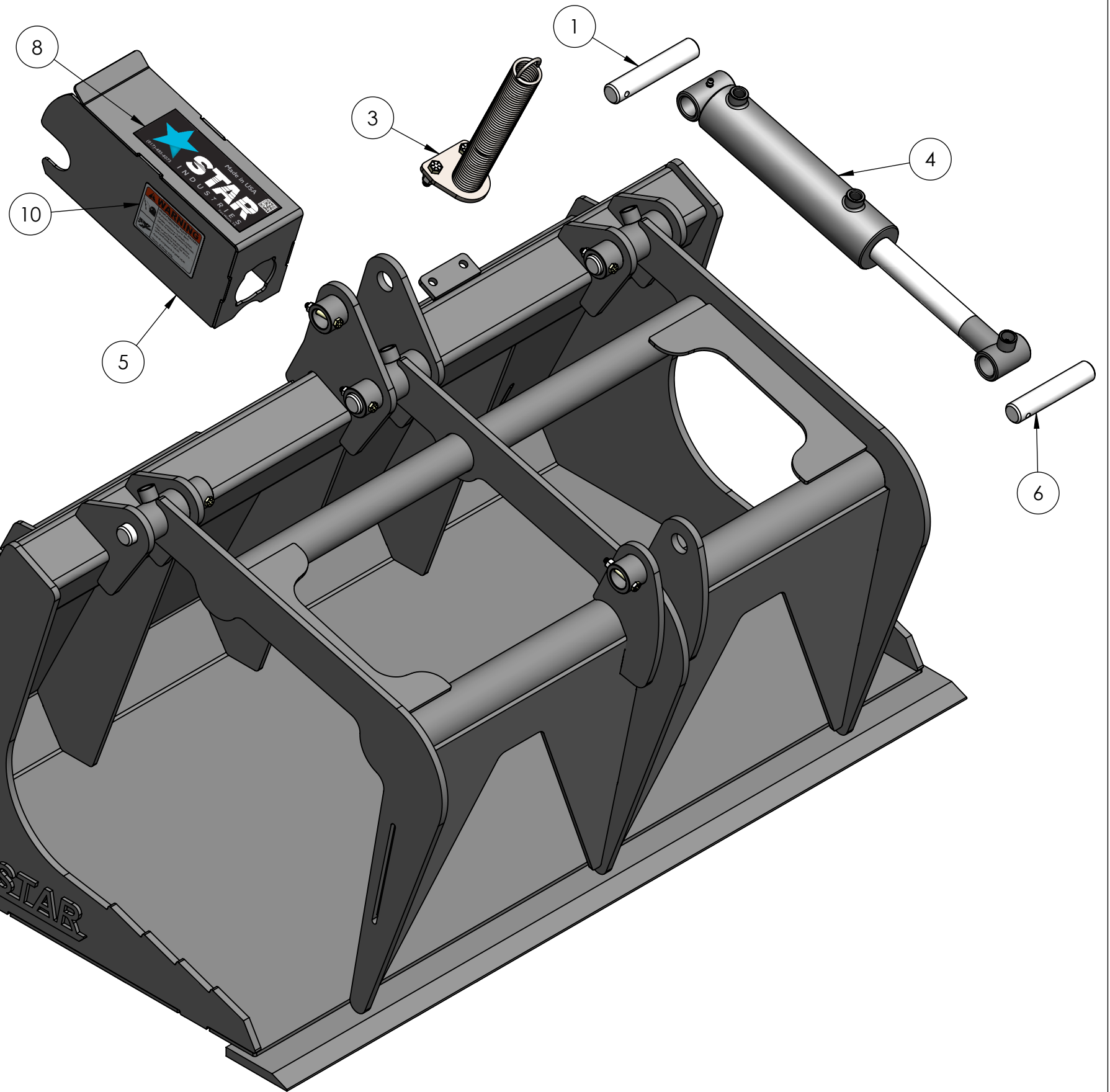



STAR
 INDUSTRIES
 Phone: (800) 541-1797
 (817) 485-6073
 Fax: (817) 428-6008
 4101 Garland Dr. Fort Worth, TX 76117 Email: mail@starindustries.com

Parts Diagram

PROPRIETARY AND CONFIDENTIAL
 THE INFORMATION CONTAINED IN THIS
 DRAWING IS THE SOLE PROPERTY OF
 STAR INDUSTRIES. ANY REPRODUCTION
 IN PART OR AS A WHOLE WITHOUT
 THE WRITTEN PERMISSION OF STAR
 INDUSTRIES IS PROHIBITED.

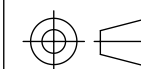
TITLE: 44" WIDE MINI GRAPPLE BUCKET BOBCAT



P-WEIGHT:
351.17 lbs.

DWG. NO.
175-MIBC-44