

ITEM NO.	PART NUMBER	DESCRIPTION	QTY.
1	1000-0108DBL	DUAL 10-1/4" x 1" LOCKING PINS W/HAIR PINS	2
2	1000-0117	5/16" SAFETY CHAIN ASSEMBLY NEW	2
3	1000-0231	3/4" - 7 TON BOLTED ANCHOR SHACKLE	3
4	1000-0260	5 TON SWIVEL HOOK W/LATCH	3
5	1000-70111	OPERATOR'S MANUAL CANISTER 2.67 DIA	1
6	1140-05	Decal Kit for 1140 Spreader Bar	2
7	DEC10000	DANGER - RETAINING PIN	1
8	DEC10001	CAUTION - READ OPERATOR'S MANUAL	1
9	DEC10006	STAR LOGO DECAL	4
10	DEC10024	OSHA DECAL	2

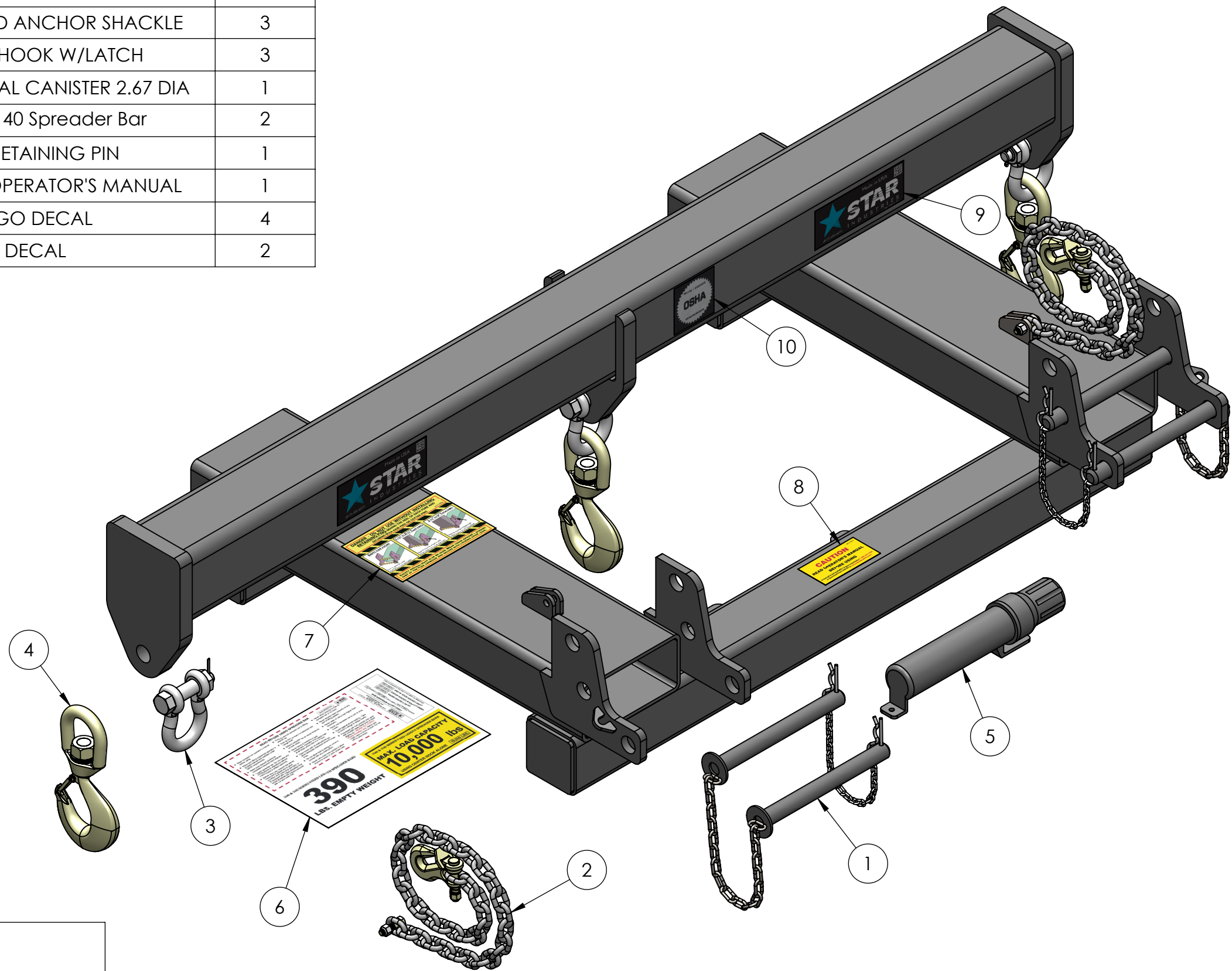



STAR
 INDUSTRIES
 Phone: (800) 541-1797
 (817) 485-6073
 Fax: (817) 428-6008
 4101 Garland Dr. Fort Worth, TX 76117 Email: mail@starindustries.com

Parts Diagram

PROPRIETARY AND CONFIDENTIAL
 THE INFORMATION CONTAINED IN THIS DRAWING IS THE SOLE PROPERTY OF STAR INDUSTRIES. ANY REPRODUCTION IN PART OR AS A WHOLE WITHOUT THE WRITTEN PERMISSION OF STAR INDUSTRIES IS PROHIBITED.

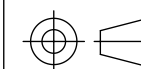
TITLE: Forklift Spreader Bar 10K 72" Fixed Length -Fork Pockets 39" CC



P-WEIGHT:
 396.73 lbs.

DWG. NO.

1140