

ITEM NO.	PART NUMBER	DESCRIPTION	QTY.
1	30-8947T44	OVAL SHAPED THREADED CONN LINK 9/32	1
2	1000-0117	5/16" SAFETY CHAIN ASSEMBLY NEW	1
3	1800-10A	16" LATCH ASSEMBLY	1
4	1800-17	SELF DUMP ROPE	1
5	1805N-05	Decal Kit for 1805N SD Hopper	1
6	DEC10001	CAUTION - READ OPERATOR'S MANUAL	1
7	DEC10006	STAR LOGO DECAL	2
8	DEC10018	SECURE TO FORKLIFT DECAL	1
9	PRT10063	SAFETY CHAIN	1

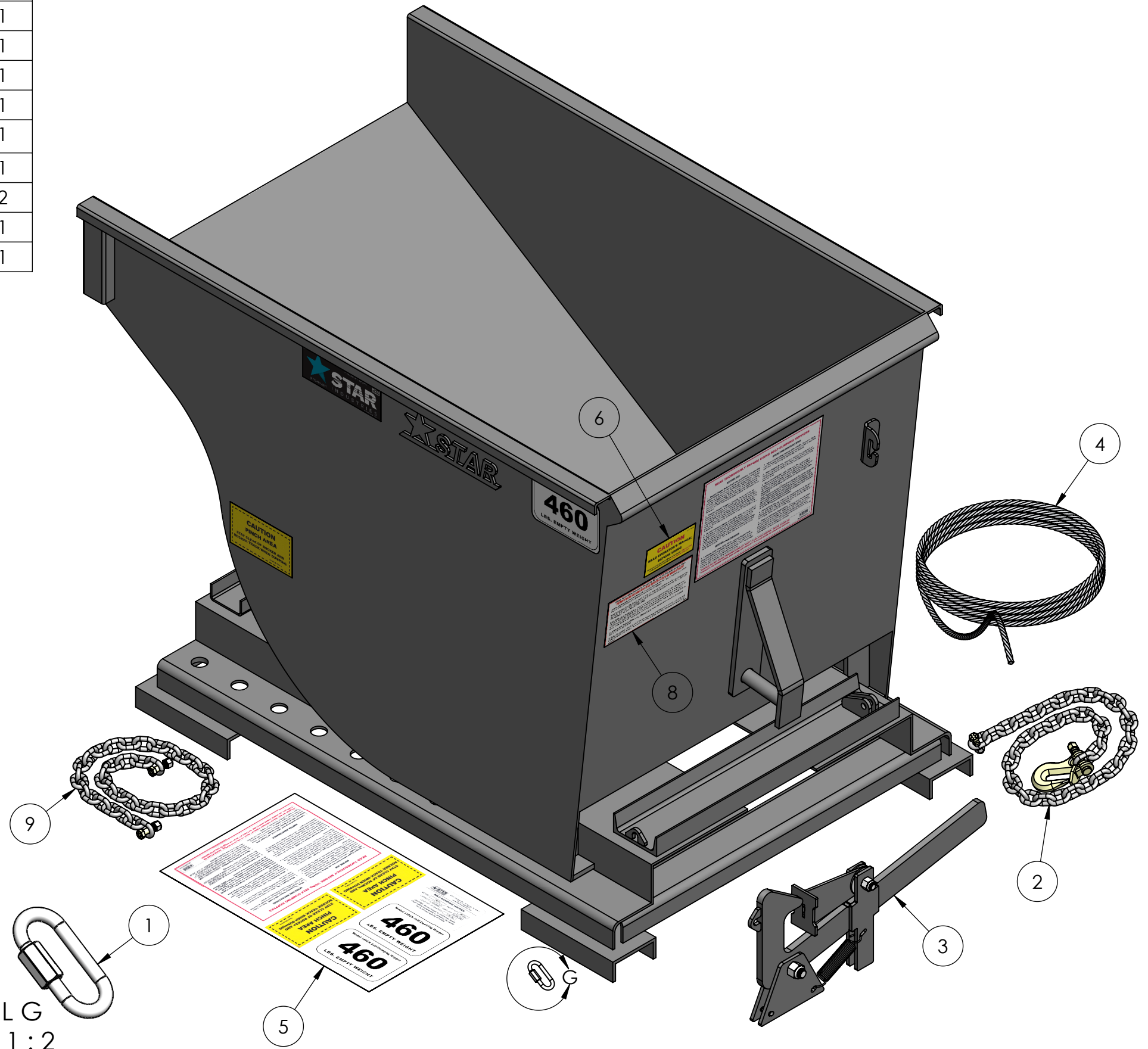

DETAIL G
SCALE 1 : 2

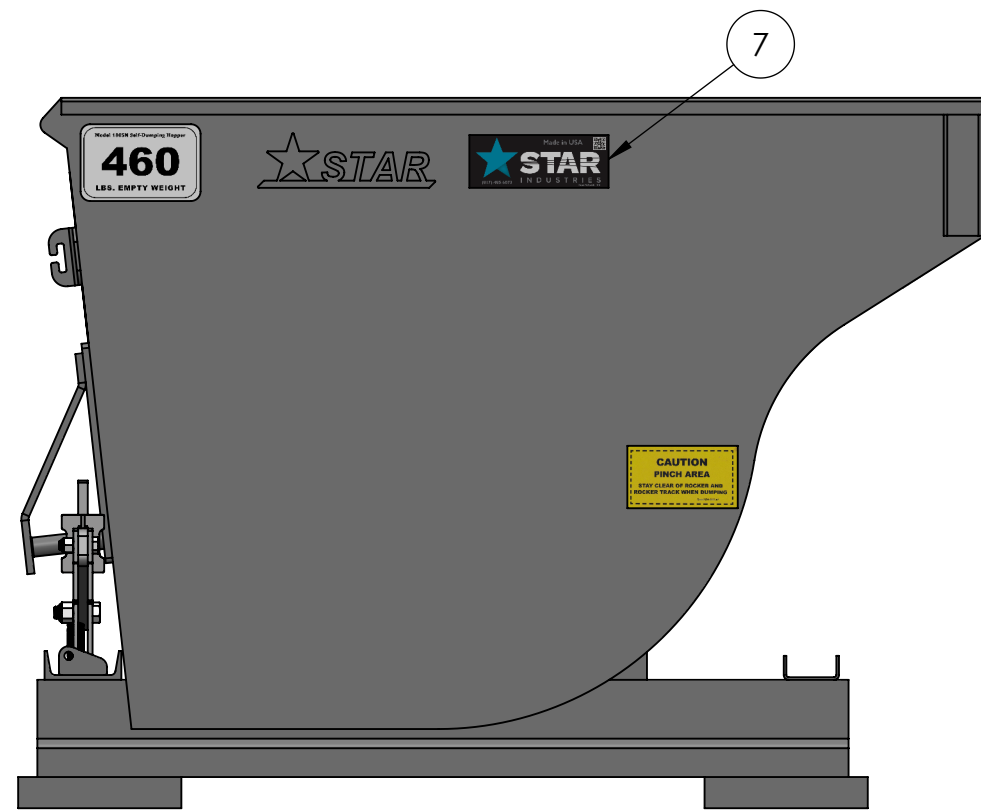
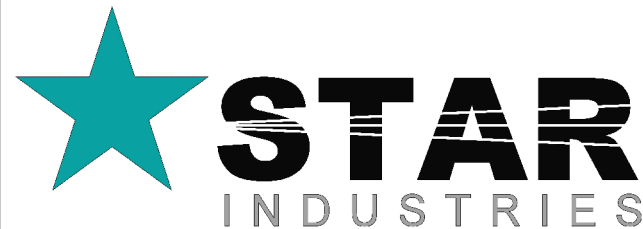

Phone: (800) 541-1797
(817) 485-6073
Fax: (817) 428-6008

4101 Garland Dr. Fort Worth, TX 76117 Email: mail@starindustries.com

Parts Diagram

PROPRIETARY AND CONFIDENTIAL
THE INFORMATION CONTAINED IN THIS
DRAWING IS THE SOLE PROPERTY OF
STAR INDUSTRIES. ANY REPRODUCTION
IN PART OR AS A WHOLE WITHOUT
THE WRITTEN PERMISSION OF STAR
INDUSTRIES IS PROHIBITED.

TITLE:

1/2CY NARROW SELF DUMP HOPPER

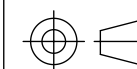

P-WEIGHT:
477.09 lbs.

DWG. NO.

1805N